

APPENDIX A  
Pavement Design

## Pavement Design

### **Mainline & Approaches:**

- Asphalt surface and top layer of asphalt base shall use PG76-22 Binder. Remaining layers of asphalt base shall use PG64-22 Binder
- Any portion of the existing driving lane pavement that will be utilized in the final roadway pavement structure shall be overlaid with a minimum of 3.25" asphalt base and 1.25" asphalt surface. Leveling and Wedging shall be specified as necessary.

#### Option 1

8" Chemically Stabilized Roadbed

4" Dense Graded Aggregate

4" Drainage Blanket – Ty II

10.75" Asphalt Base - CL3 1.00D (4" + 3.5" + 3.25")

1.25" Asphalt Surface - CL3 0.38A PG76-22

#### Option 2

12" Rock (#2's, 3's or 23's) wrapped in Geotextile Fabric Type IV

4" Crushed Stone Base

13" Asphalt Base - CL3 1.00D (3"+3"+3.5"+3.25")

1.25" Asphalt Surface - CL3 0.38A PG76-22

#### Option 3

Geotextile Fabric Type IV

Geogrid Reinforcement (Section 304 or Tensar TX5/TX7)

12" Crushed Stone Base (minimum 8" first lift)

10" Asphalt Base - CL3 1.00D (3.25"+3.5"+3.25")

1.25" Asphalt Surface - CL3 0.38A PG76-22

### **Shared Use Path:**

1.25" CL3 Asphalt Surface 0.38A PG76-22

6" Crushed Stone Base

APPENDIX B  
Typical Section

# TYPICAL SECTIONS

KY245 OPTION #1 DESIGN SPEED = 45 m.p.h.

NOTES:

COUNTY OF	ITEM NO.	SHEET NO.
NELSON	4-8307.10	R2

- SEE CROSS-SECTIONS FOR SLOPES OUTSIDE OF SHOULDER.
- WIDEN SHOULDER 2' FOR GUARDRAIL
- ASPHALT PAVE MILLING AND TEXTURING (18" WIDE AND 3.50" DEEP) SHALL BE REQUIRED ALONG THE EDGE OF THE EXISTING PAVEMENT ADJACENT TO THE WIDENING. BACKFILL WITH THE ASPHALT BASE ON THE SAME PASS AS THE WIDENING. PAYMENT FOR THIS WORK WILL BE AT THE UNIT PRICE BID PER TON FOR MILLING.
- SLOPE DRAINAGE BLANKET AND DGA AWAY FROM EXISTING PAVEMENT EDGE TO PROVIDE SUBGRADE DRAINAGE WHERE WATER MAY BECOME IMPOUNDED AGAINST THE EXISTING PAVEMENT.

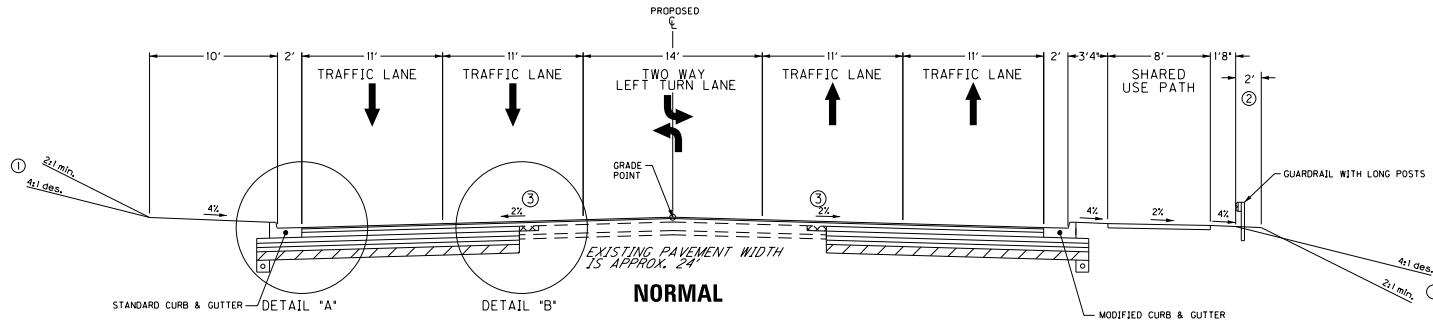

**NORMAL**

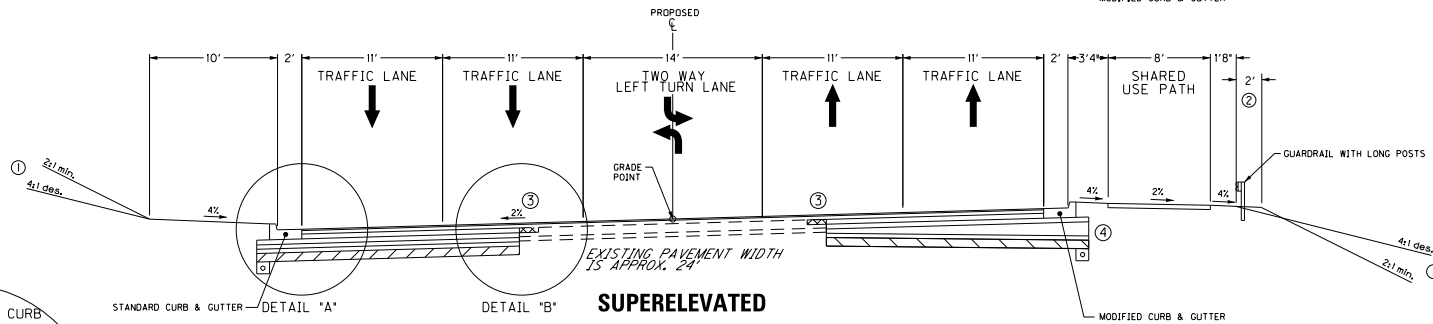

**SUPERELEVATED**

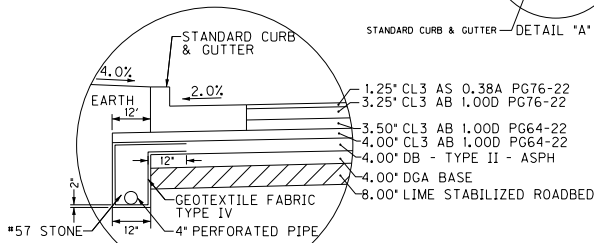

**DETAIL "A"**

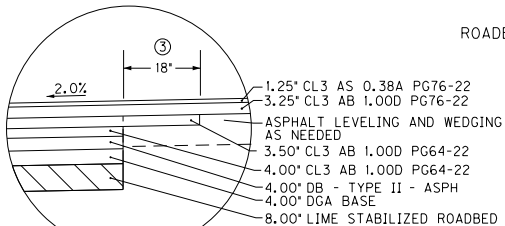

**DETAIL "B"**

## PAVEMENT SCHEDULE

OVERALL	1.25" CL3 ASPHALT SURFACE 0.38A PG76-22 3.25" CL3 ASPHALT BASE 1.000 PG76-22 VAR-LEVELING AND WEDGING
TRAFFIC LANES WIDENING	3.50" CL3 ASPHALT BASE 1.000 PG64-22 4.00" CL3 ASPHALT BASE 1.000 PG64-22 4.00" DRAINAGE BLANKET - TYPE II - ASPH 4.00" DENSE GRADED AGGREGATE
ROADBED PREPARATION	8" LIME STABILIZED ROADBED LIME (APPLY AT A RATE OF 6% BY WEIGHT AT 100 LB/CU.FT.)
ASPHALT CURING SEAL	2.0 LB/SO. YD. SAND FOR BLOTTER 5.0 LB/SO. YD.
SHARED USE PATH	1.25" CL3 ASPHALT SURFACE 0.38A PG76-22 6.00" CRUSHED STONE BASE

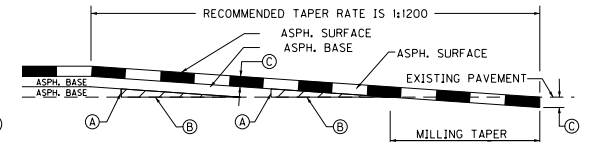

- MINIMUM COMPACTED THICKNESS
- ASPHALT MIXTURE FOR LEVELING AND WEDGING OR NEXT COURSE OF ASPHALT MIXTURE.
- ASPHALT SURFACE THICKNESS (FULL DEPTH)
- MILL EXISTING PAVEMENT TO RECEIVE ASPHALT SURFACE FULL DEPTH (EDGE KEY). TAPER LENGTH (ft) =  $\frac{1.25 \text{ (in)} \times \text{TAPER RATE}}{12}$

FOR A TAPER RATE OF 1:1200  
TAPER LENGTH = 125 FEET WHEN  $t = 1.25$  inches

**TAPERING OF OVERLAYS ON HIGH SPEED FACILITIES ( $\geq 45$  MPH)**

TYPICAL SECTIONS

# TYPICAL SECTIONS

KY245 OPTION #2 DESIGN SPEED = 45 m.p.h.

NOTES:

COUNTY OF	ITEM NO.	SHEET NO.
NELSON	4-8307.10	R2

- ① SEE CROSS-SECTIONS FOR SLOPES OUTSIDE OF SHOULDER.
- ② WIDEN SHOULDER 2' FOR GUARDRAIL
- ③ ASPHALT PAVE MILLING AND TEXTURING (18" WIDE AND 3.50" DEEP) SHALL BE REQUIRED ALONG THE EDGE OF THE EXISTING PAVEMENT ADJACENT TO THE WIDENING. BACKFILL WITH THE ASPHALT BASE ON THE SAME PASS AS THE WIDENING. PAYMENT FOR THIS WORK WILL BE AT THE UNIT PRICE BID PER TON FOR MILLING.
- ④ SLOPE CSB AND ROCK ROADBED AWAY FROM EXISTING PAVEMENT EDGE TO PROVIDE SUBGRADE DRAINAGE WHERE WATER MAY BECOME IMPOUNDED AGAINST THE EXISTING PAVEMENT.
- ⑤ USE MIN. FABRIC WIDTH NECESSARY TO ALLOW FOR A 1' OVERLAP

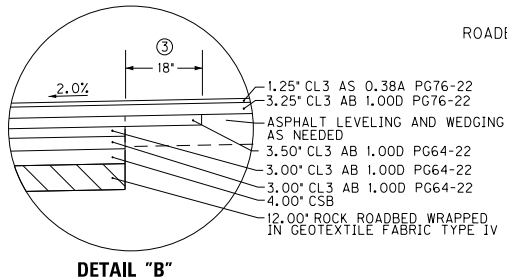
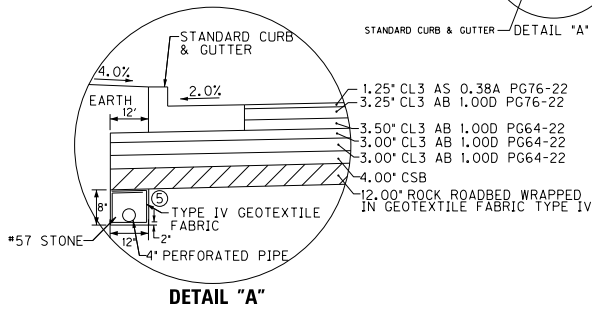
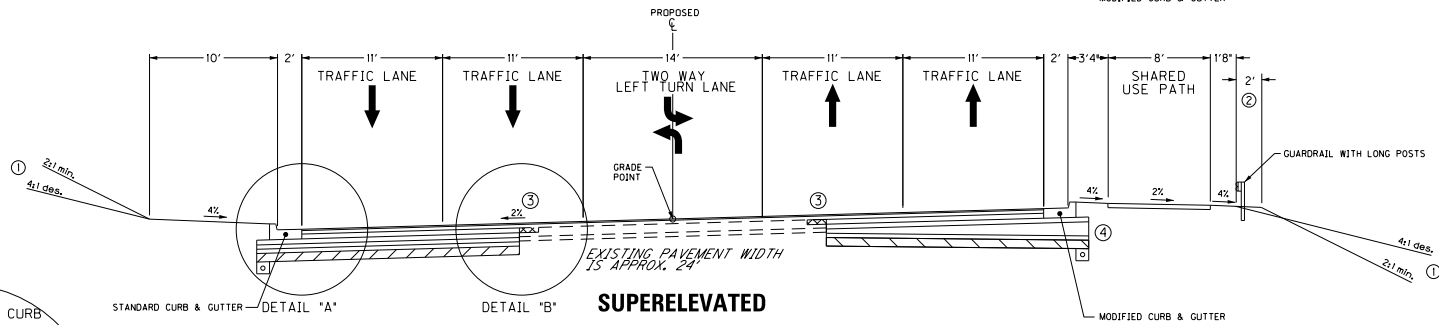
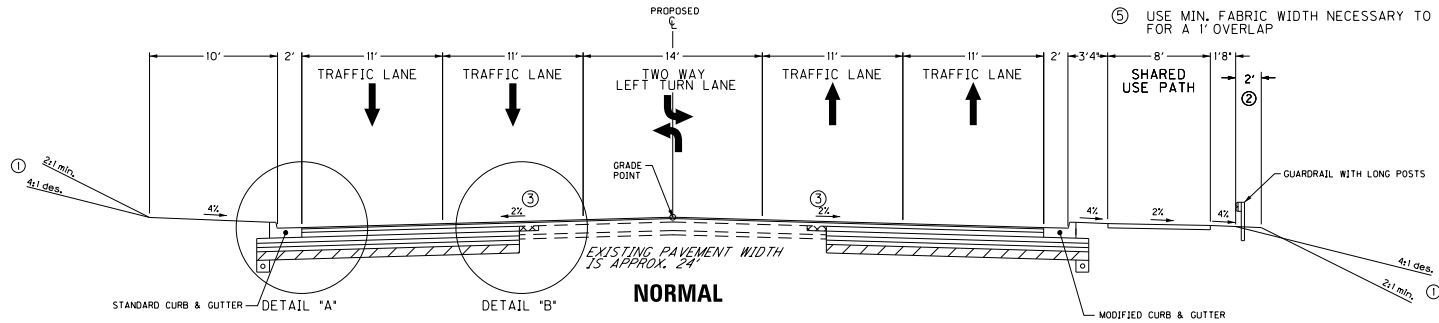

## PAVEMENT SCHEDULE

OVERALL	1.25" CL3 ASPHALT SURFACE 0.38A PG76-22 3.25" CL3 ASPHALT BASE 1.00D PG76-22 VAR-LEVELING AND WEDGING
TRAFFIC LANES WIDENING	3.50" CL3 ASPHALT BASE 1.00D PG64-22 3.00" CL3 ASPHALT BASE 1.00D PG64-22 3.00" CL3 ASPHALT BASE 1.00D PG64-22 4.00" CRUSHED STONE BASE
ROADBED PREPARATION	12.00" ROCK ROADBED WRAPPED IN GEOTEXTILE FABRIC TYPE IV
SHARED USE PATH	1.25" CL3 ASPHALT SURFACE 0.38A PG76-22 6.00" CRUSHED STONE BASE

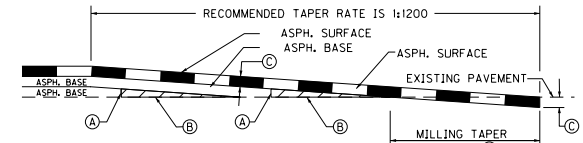

- (A) MINIMUM COMPACTED THICKNESS  
 (B) ASPHALT MIXTURE FOR LEVELING AND WEDGING OR NEXT COURSE OF ASPHALT MIXTURE.  
 (C) ASPHALT SURFACE THICKNESS (FULL DEPTH)  
 (D) MILL EXISTING PAVEMENT TO RECEIVE ASPHALT SURFACE FULL DEPTH (EDGE KEY).  
 TAPER LENGTH (ft) =  $\frac{1.25 \text{ (in)} \times \text{TAPER RATE}}{12}$

FOR A TAPER RATE OF 1:1200  
 TAPER LENGTH = 125 FEET WHEN  $t = 1.25$  inches

## TAPERING OF OVERLAYS ON HIGH SPEED FACILITIES ( $\geq 45$ MPH)

# TYPICAL SECTIONS

KY245 OPTION #3 DESIGN SPEED = 45 m.p.h.

NOTES:

COUNTY OF	ITEM NO.	SHEET NO.
NELSON	4-8307.10	R2

- SEE CROSS-SECTIONS FOR SLOPES OUTSIDE OF SHOULDER.
- WIDEN SHOULDER 2' FOR GUARDRAIL
- ASPHALT PAVE MILLING AND TEXTURING (18" WIDE AND 3.50" DEEP) SHALL BE REQUIRED ALONG THE EDGE OF THE EXISTING PAVEMENT ADJACENT TO THE WIDENING. BACKFILL WITH THE ASPHALT BASE ON THE SAME PASS AS THE WIDENING. PAYMENT FOR THIS WORK WILL BE AT THE UNIT PRICE BID PER TON FOR MILLING.
- SLOPE CSB AWAY FROM EXISTING PAVEMENT EDGE TO PROVIDE SUBGRADE DRAINAGE WHERE WATER MAY BECOME IMPOUNDED AGAINST THE EXISTING PAVEMENT.
- USE MIN. FABRIC WIDTH NECESSARY TO ALLOW FOR A 1' OVERLAP

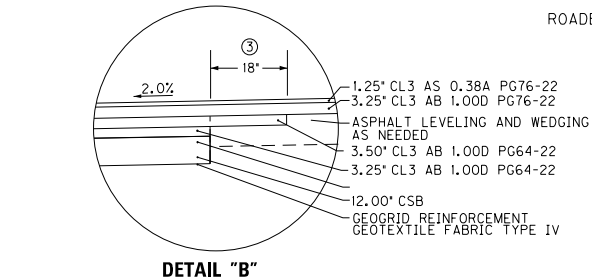
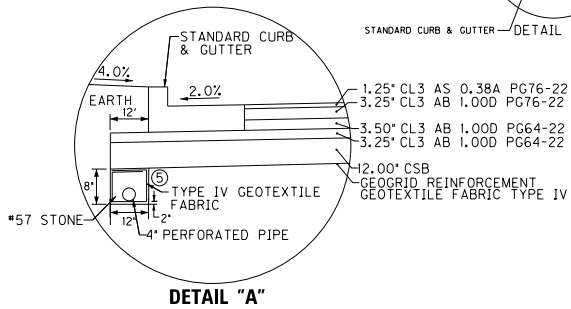
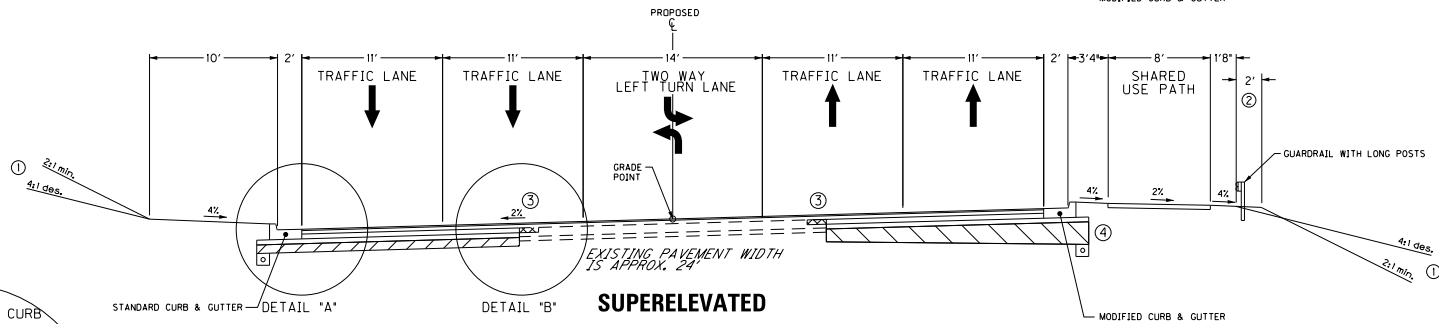
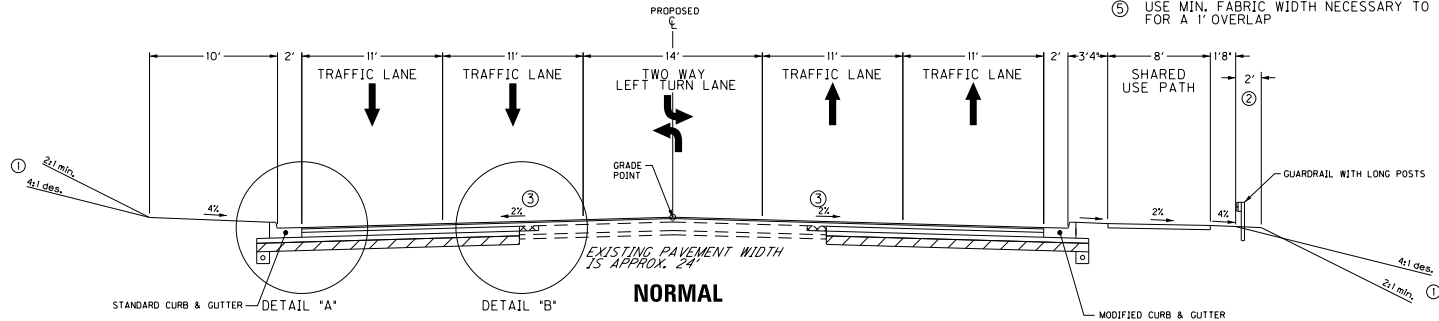

## PAVEMENT SCHEDULE

OVERALL	1.25" CL3 ASPHALT SURFACE 0.38A PG76-22 3.25" CL3 ASPHALT BASE 1.00D PG76-22 VAR-LEVELING AND WEDGING
TRAFFIC LANES WIDENING	3.50" CL3 ASPHALT BASE 1.00D PG64-22 3.25" CL3 ASPHALT BASE 1.00D PG64-22 12.00" CRUSHED STONE BASE
ROADBED PREPARATION	GEOGRID REINFORCEMENT GEOTEXTILE FABRIC TYPE IV
SHARED USE PATH	1.25" CL3 ASPHALT SURFACE 0.38A PG76-22 6.00" CRUSHED STONE BASE

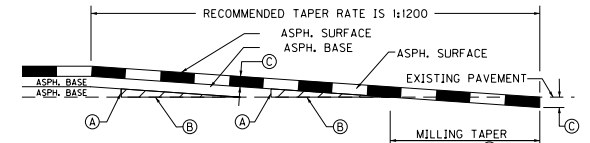

- MINIMUM COMPACTED THICKNESS
- ASPHALT MIXTURE FOR LEVELING AND WEDGING OR NEXT COURSE OF ASPHALT MIXTURE.
- ASPHALT SURFACE THICKNESS (FULL DEPTH)
- MILL EXISTING PAVEMENT TO RECEIVE ASPHALT SURFACE FULL DEPTH (EDGE KEY).  
TAPER LENGTH (ft) =  $\frac{1.25 \text{ (in)} \times \text{TAPER RATE}}{12}$

FOR A TAPER RATE OF 1:1200  
TAPER LENGTH = 125 FEET WHEN  $t = 1.25$  inches

## TAPERING OF OVERLAYS ON HIGH SPEED FACILITIES ( $\geq 45$ MPH)

TYPICAL SECTIONS

## APPENDIX C

### Nationwide Permit Conditions

## **Nationwide Permit #14 –Linear Transportation Projects**

Activities required for the construction, expansion, modification, or improvement of linear transportation projects (e.g., roads, highways, railways, trails, airport runways, and taxiways) in waters of the United States. For linear transportation projects in non-tidal waters, the discharge cannot cause the loss of greater than 1/2-acre of waters of the United States. For linear transportation projects in tidal waters, the discharge cannot cause the loss of greater than 1/3-acre of waters of the United States. Any stream channel modification, including bank stabilization, is limited to the minimum necessary to construct or protect the linear transportation project; such modifications must be in the immediate vicinity of the project.

This NWP also authorizes temporary structures, fills, and work necessary to construct the linear transportation project. Appropriate measures must be taken to maintain normal downstream flows and minimize flooding to the maximum extent practicable, when temporary structures, work, and discharges, including cofferdams, are necessary for construction activities, access fills, or dewatering of construction sites. Temporary fills must consist of materials, and be placed in a manner, that will not be eroded by expected high flows. Temporary fills must be removed in their entirety and the affected areas returned to pre-construction elevations. The areas affected by temporary fills must be revegetated, as appropriate.

This NWP cannot be used to authorize non-linear features commonly associated with transportation projects, such as vehicle maintenance or storage buildings, parking lots, train stations, or aircraft hangars.

Notification: The permittee must submit a pre-construction notification to the district engineer prior to commencing the activity if: (1) the loss of waters of the United States exceeds 1/10-acre; or (2) there is a discharge in a special aquatic site, including wetlands. (See general condition 31.) (Sections 10 and 404)

Note: Some discharges for the construction of farm roads or forest roads, or temporary roads for moving mining equipment, may qualify for an exemption under Section 404(f) of the Clean Water Act (see 33 CFR 323.4).

## **Nationwide Permit General Conditions**

Note: To qualify for NWP authorization, the prospective permittee must comply with the following general conditions, as applicable, in addition to any regional or case-specific conditions imposed by the division engineer or district engineer. Prospective permittees should contact the appropriate Corps district office to determine if regional conditions have been imposed on an NWP. Prospective permittees should also contact the appropriate Corps district office to determine the status of Clean Water Act Section 401 water quality certification and/or Coastal Zone Management Act consistency for an NWP. Every person who may wish to obtain permit authorization under one or more NWPs, or who is currently relying on an existing or prior permit authorization under one or more NWPs, has been and is on notice that all of the provisions of 33 CFR §§ 330.1 through 330.6 apply to every NWP authorization. Note especially 33 CFR § 330.5 relating to the modification, suspension, or revocation of any NWP authorization.

1. Navigation. (a) No activity may cause more than a minimal adverse effect on



navigation.

(b) Any safety lights and signals prescribed by the U.S. Coast Guard, through regulations or otherwise, must be installed and maintained at the permittee's expense on authorized facilities in navigable waters of the United States.

(c) The permittee understands and agrees that, if future operations by the United States require the removal, relocation, or other alteration, of the structure or work herein authorized, or if, in the opinion of the Secretary of the Army or his authorized representative, said structure or work shall cause unreasonable obstruction to the free navigation of the navigable waters, the permittee will be required, upon due notice from the Corps of Engineers, to remove, relocate, or alter the structural work or obstructions caused thereby, without expense to the United States. No claim shall be made against the United States on account of any such removal or alteration.

2. Aquatic Life Movements. No activity may substantially disrupt the necessary life cycle movements of those species of aquatic life indigenous to the waterbody, including those species that normally migrate through the area, unless the activity's primary purpose is to impound water. All permanent and temporary crossings of waterbodies shall be suitably culverted, bridged, or otherwise designed and constructed to maintain low flows to sustain the movement of those aquatic species.

3. Spawning Areas. Activities in spawning areas during spawning seasons must be avoided to the maximum extent practicable. Activities that result in the physical destruction (e.g., through excavation, fill, or downstream smothering by substantial turbidity) of an important spawning area are not authorized.

4. Migratory Bird Breeding Areas. Activities in waters of the United States that serve as breeding areas for migratory birds must be avoided to the maximum extent practicable.

5. Shellfish Beds. No activity may occur in areas of concentrated shellfish populations, unless the activity is directly related to a shellfish harvesting activity authorized by NWP 4 and 48, or is a shellfish seeding or habitat restoration activity authorized by NWP 27.

6. Suitable Material. No activity may use unsuitable material (e.g., trash, debris, car bodies, asphalt, etc.). Material used for construction or discharged must be free from toxic pollutants in toxic amounts (see Section 307 of the Clean Water Act).

7. Water Supply Intakes. No activity may occur in the proximity of a public water supply intake, except where the activity is for the repair or improvement of public water supply intake structures or adjacent bank stabilization.

8. Adverse Effects From Impoundments. If the activity creates an impoundment of water, adverse effects to the aquatic system due to accelerating the passage of water, and/or restricting its flow must be minimized to the maximum extent practicable.

9. Management of Water Flows. To the maximum extent practicable, the pre-construction course, condition, capacity, and location of open waters must be maintained for each activity, including stream channelization and storm water management activities, except as provided below. The activity must be constructed to withstand expected high flows. The activity must not restrict or impede the passage of normal or high flows, unless the primary purpose of the activity is to impound water or manage high flows. The activity may alter the pre-construction course, condition, capacity, and location of open waters if it benefits the aquatic environment (e.g., stream restoration or relocation activities).

10. Fills Within 100-Year Floodplains. The activity must comply with applicable FEMA- approved state or local floodplain management requirements.

11. Equipment. Heavy equipment working in wetlands or mudflats must be placed on mats, or other measures must be taken to minimize soil disturbance.

12. Soil Erosion and Sediment Controls. Appropriate soil erosion and sediment controls must be used and maintained in effective operating condition during construction, and all exposed soil and other fills, as well as any work below the ordinary high water mark or high tide line, must be permanently stabilized at the earliest practicable date. Permittees are encouraged to perform work within waters of the United States during periods of low-flow or no-flow.

13. Removal of Temporary Fills. Temporary fills must be removed in their entirety and the affected areas returned to pre-construction elevations. The affected areas must be revegetated, as appropriate.

14. Proper Maintenance. Any authorized structure or fill shall be properly maintained, including maintenance to ensure public safety and compliance with applicable NWP general conditions, as well as any activity-specific conditions added by the district engineer to an NWP authorization.

15. Single and Complete Project. The activity must be a single and complete project. The same NWP cannot be used more than once for the same single and complete project.

16. Wild and Scenic Rivers. No activity may occur in a component of the National Wild and Scenic River System, or in a river officially designated by Congress as a “study river” for possible inclusion in the system while the river is in an official study status, unless the

appropriate Federal agency with direct management responsibility for such river, has determined in writing that the proposed activity will not adversely affect the Wild and Scenic River designation or study status. Information on Wild and Scenic Rivers may be obtained from the appropriate Federal land management agency responsible for the designated Wild and Scenic River or study river (e.g., National Park Service, U.S. Forest Service, Bureau of Land Management, U.S. Fish and Wildlife Service).

17. Tribal Rights. No activity or its operation may impair reserved tribal rights, including, but not limited to, reserved water rights and treaty fishing and hunting rights.

18. Endangered Species. (a) No activity is authorized under any NWP which is likely to directly or indirectly jeopardize the continued existence of a threatened or endangered species or a species proposed for such designation, as identified under the Federal Endangered Species Act (ESA), or which will directly or indirectly destroy or adversely modify the critical habitat of such species. No activity is authorized under any NWP which “may affect” a listed species or critical habitat, unless Section 7 consultation addressing the effects of the proposed activity has been completed.

(b) Federal agencies should follow their own procedures for complying with the requirements of the ESA. Federal permittees must provide the district engineer with the appropriate documentation to demonstrate compliance with those requirements. The district engineer will review the documentation and determine whether it is sufficient to address ESA compliance for the NWP activity, or whether additional ESA consultation is necessary.

(c) Non-federal permittees must submit a pre-construction notification to the district engineer if any listed species or designated critical habitat might be affected or is in the vicinity of the project, or if the project is located in designated critical habitat, and shall not begin work on the activity until notified by the district engineer that the requirements of the ESA have been satisfied and that the activity is authorized. For activities that might affect Federally-listed endangered or threatened species or designated critical habitat, the pre-construction notification must include the name(s) of the endangered or threatened species that might be affected by the proposed work or that utilize the designated critical habitat that might be affected by the proposed work. The district engineer will determine whether the proposed activity “may affect” or will have “no effect” to listed species and designated critical habitat and will notify the non-Federal applicant of the Corps’ determination within 45 days of receipt of a complete pre-construction notification. In cases where the non-Federal applicant has identified listed species or critical habitat that might be affected or is in the vicinity of the project, and has so notified the Corps, the applicant shall not begin work until the Corps has provided notification the proposed activities will have “no effect” on listed species or critical habitat, or until Section 7 consultation has been completed. If the non-Federal applicant has not heard back from the Corps within 45 days, the applicant must still wait for notification from the Corps.

(d) As a result of formal or informal consultation with the FWS or NMFS the district engineer may add species-specific regional endangered species conditions to the NWPs.

(e) Authorization of an activity by a NWP does not authorize the “take” of a threatened or endangered species as defined under the ESA. In the absence of separate authorization (e.g.,

an ESA Section 10 Permit, a Biological Opinion with “incidental take” provisions, etc.) from the U.S. FWS or the NMFS, The Endangered Species Act prohibits any person subject to the jurisdiction of the United States to take a listed species, where "take" means to harass, harm, pursue, hunt, shoot, wound, kill, trap, capture, or collect, or to attempt to engage in any such conduct. The word “harm” in the definition of “take” means an act which actually kills or injures wildlife. Such an act may include significant habitat modification or degradation where it actually kills or injures wildlife by significantly impairing essential behavioral patterns, including breeding, feeding or sheltering.

(f) Information on the location of threatened and endangered species and their critical habitat can be obtained directly from the offices of the U.S. FWS and NMFS or their world wide web pages at <http://www.fws.gov/> or <http://www.fws.gov/ipac> and <http://www.noaa.gov/fisheries.html> respectively.

19. Migratory Birds and Bald and Golden Eagles. The permittee is responsible for obtaining any “take” permits required under the U.S. Fish and Wildlife Service’s regulations governing compliance with the Migratory Bird Treaty Act or the Bald and Golden Eagle Protection Act. The permittee should contact the appropriate local office of the U.S. Fish and Wildlife Service to determine if such “take” permits are required for a particular activity.

20. Historic Properties. (a) In cases where the district engineer determines that the activity may affect properties listed, or eligible for listing, in the National Register of Historic Places, the activity is not authorized, until the requirements of Section 106 of the National Historic Preservation Act (NHPA) have been satisfied.

(b) Federal permittees should follow their own procedures for complying with the requirements of Section 106 of the National Historic Preservation Act. Federal permittees must provide the district engineer with the appropriate documentation to demonstrate compliance with those requirements. The district engineer will review the documentation and determine whether it is sufficient to address section 106 compliance for the NWP activity, or whether additional section 106 consultation is necessary.

(c) Non-federal permittees must submit a pre-construction notification to the district engineer if the authorized activity may have the potential to cause effects to any historic properties listed on, determined to be eligible for listing on, or potentially eligible for listing on the National Register of Historic Places, including previously unidentified properties. For such activities, the pre-construction notification must state which historic properties may be affected by the proposed work or include a vicinity map indicating the location of the historic properties or the potential for the presence of historic properties. Assistance regarding information on the location of or potential for the presence of historic resources can be sought from the State Historic Preservation Officer or Tribal Historic Preservation Officer, as appropriate, and the National Register of Historic Places (see 33 CFR 330.4(g)). When reviewing pre-construction notifications, district engineers will comply with the current procedures for addressing the requirements of Section 106 of the National Historic Preservation Act. The district engineer shall make a reasonable and good faith effort to carry out appropriate identification efforts, which may include background research, consultation, oral history interviews, sample field

investigation, and field survey. Based on the information submitted and these efforts, the district engineer shall determine whether the proposed activity has the potential to cause an effect on the historic properties. Where the non-Federal applicant has identified historic properties on which the activity may have the potential to cause effects and so notified the Corps, the non-Federal applicant shall not begin the activity until notified by the district engineer either that the activity has no potential to cause effects or that consultation under Section 106 of the NHPA has been completed.

(d) The district engineer will notify the prospective permittee within 45 days of receipt of a complete pre-construction notification whether NHPA Section 106 consultation is required. Section 106 consultation is not required when the Corps determines that the activity does not have the potential to cause effects on historic properties (see 36 CFR §800.3(a)). If NHPA section 106 consultation is required and will occur, the district engineer will notify the non-Federal applicant that he or she cannot begin work until Section 106 consultation is completed. If the non-Federal applicant has not heard back from the Corps within 45 days, the applicant must still wait for notification from the Corps.

(e) Prospective permittees should be aware that section 110k of the NHPA (16 U.S.C. 470h-2(k)) prevents the Corps from granting a permit or other assistance to an applicant who, with intent to avoid the requirements of Section 106 of the NHPA, has intentionally significantly adversely affected a historic property to which the permit would relate, or having legal power to prevent it, allowed such significant adverse effect to occur, unless the Corps, after consultation with the Advisory Council on Historic Preservation (ACHP), determines that circumstances justify granting such assistance despite the adverse effect created or permitted by the applicant. If circumstances justify granting the assistance, the Corps is required to notify the ACHP and provide documentation specifying the circumstances, the degree of damage to the integrity of any historic properties affected, and proposed mitigation. This documentation must include any views obtained from the applicant, SHPO/THPO, appropriate Indian tribes if the undertaking occurs on or affects historic properties on tribal lands or affects properties of interest to those tribes, and other parties known to have a legitimate interest in the impacts to the permitted activity on historic properties.

21. Discovery of Previously Unknown Remains and Artifacts. If you discover any previously unknown historic, cultural or archeological remains and artifacts while accomplishing the activity authorized by this permit, you must immediately notify the district engineer of what you have found, and to the maximum extent practicable, avoid construction activities that may affect the remains and artifacts until the required coordination has been completed. The district engineer will initiate the Federal, Tribal and state coordination required to determine if the items or remains warrant a recovery effort or if the site is eligible for listing in the National Register of Historic Places.

22. Designated Critical Resource Waters. Critical resource waters include, NOAA-managed marine sanctuaries and marine monuments, and National Estuarine Research Reserves. The district engineer may designate, after notice and opportunity for public comment, additional waters officially designated by a state as having particular environmental or ecological significance, such as outstanding national resource waters or state natural heritage

sites. The district engineer may also designate additional critical resource waters after notice and opportunity for public comment.

(a) Discharges of dredged or fill material into waters of the United States are not authorized by NWRPs 7, 12, 14, 16, 17, 21, 29, 31, 35, 39, 40, 42, 43, 44, 49, 50, 51, and 52 for any activity within, or directly affecting, critical resource waters, including wetlands adjacent to such waters.

(b) For NWRPs 3, 8, 10, 13, 15, 18, 19, 22, 23, 25, 27, 28, 30, 33, 34, 36, 37, and 38, notification is required in accordance with general condition 31, for any activity proposed in the designated critical resource waters including wetlands adjacent to those waters. The district engineer may authorize activities under these NWRPs only after it is determined that the impacts to the critical resource waters will be no more than minimal.

23. Mitigation. The district engineer will consider the following factors when determining appropriate and practicable mitigation necessary to ensure that adverse effects on the aquatic environment are minimal:

(a) The activity must be designed and constructed to avoid and minimize adverse effects, both temporary and permanent, to waters of the United States to the maximum extent practicable at the project site (i.e., on site).

(b) Mitigation in all its forms (avoiding, minimizing, rectifying, reducing, or compensating for resource losses) will be required to the extent necessary to ensure that the adverse effects to the aquatic environment are minimal.

(c) Compensatory mitigation at a minimum one-for-one ratio will be required for all wetland losses that exceed 1/10-acre and require pre-construction notification, unless the district engineer determines in writing that either some other form of mitigation would be more environmentally appropriate or the adverse effects of the proposed activity are minimal, and provides a project-specific waiver of this requirement. For wetland losses of 1/10-acre or less that require pre-construction notification, the district engineer may determine on a case-by-case basis that compensatory mitigation is required to ensure that the activity results in minimal adverse effects on the aquatic environment. Compensatory mitigation projects provided to offset losses of aquatic resources must comply with the applicable provisions of 33 CFR part 332.

(1) The prospective permittee is responsible for proposing an appropriate compensatory mitigation option if compensatory mitigation is necessary to ensure that the activity results in minimal adverse effects on the aquatic environment.

(2) Since the likelihood of success is greater and the impacts to potentially valuable uplands are reduced, wetland restoration should be the first compensatory mitigation option considered.

(3) If permittee-responsible mitigation is the proposed option, the prospective permittee is responsible for submitting a mitigation plan. A conceptual or detailed mitigation plan may be used by the district engineer to make the decision on the NWP verification request, but a final mitigation plan that addresses the applicable requirements of 33 CFR 332.4(c)(2) – (14) must be approved by the district engineer before the permittee begins work in waters of the United States, unless the district engineer determines that prior approval of the final mitigation plan is not practicable or not necessary to ensure timely completion of the required compensatory mitigation (see 33 CFR 332.3(k)(3)).

(4) If mitigation bank or in-lieu fee program credits are the proposed option, the mitigation plan only needs to address the baseline conditions at the impact site and the number of credits to be provided.

(5) Compensatory mitigation requirements (e.g., resource type and amount to be provided as compensatory mitigation, site protection, ecological performance standards, monitoring requirements) may be addressed through conditions added to the NWP authorization, instead of components of a compensatory mitigation plan.

(d) For losses of streams or other open waters that require pre-construction notification, the district engineer may require compensatory mitigation, such as stream rehabilitation, enhancement, or preservation, to ensure that the activity results in minimal adverse effects on the aquatic environment.

(e) Compensatory mitigation will not be used to increase the acreage losses allowed by the acreage limits of the NWPs. For example, if an NWP has an acreage limit of 1/2-acre, it cannot be used to authorize any project resulting in the loss of greater than 1/2-acre of waters of the United States, even if compensatory mitigation is provided that replaces or restores some of the lost waters. However, compensatory mitigation can and should be used, as necessary, to ensure that a project already meeting the established acreage limits also satisfies the minimal impact requirement associated with the NWPs.

(f) Compensatory mitigation plans for projects in or near streams or other open waters will normally include a requirement for the restoration or establishment, maintenance, and legal protection (e.g., conservation easements) of riparian areas next to open waters. In some cases, riparian areas may be the only compensatory mitigation required. Riparian areas should consist of native species. The width of the required riparian area will address documented water quality or aquatic habitat loss concerns. Normally, the riparian area will be 25 to 50 feet wide on each side of the stream, but the district engineer may require slightly wider riparian areas to address documented water quality or habitat loss concerns. If it is not possible to establish a riparian area on both sides of a stream, or if the waterbody is a lake or coastal waters, then restoring or establishing a riparian area along a single bank or shoreline may be sufficient. Where both wetlands and open waters exist on the project site, the district engineer will determine the appropriate compensatory mitigation (e.g., riparian areas and/or wetlands compensation) based on what is best for the aquatic environment on a watershed basis. In cases where riparian areas are determined to be the most appropriate form of compensatory mitigation, the district engineer may waive or reduce the requirement to provide wetland compensatory mitigation for wetland losses.

(g) Permittees may propose the use of mitigation banks, in-lieu fee programs, or separate permittee-responsible mitigation. For activities resulting in the loss of marine or estuarine resources, permittee-responsible compensatory mitigation may be environmentally preferable if there are no mitigation banks or in-lieu fee programs in the area that have marine or estuarine credits available for sale or transfer to the permittee. For permittee-responsible mitigation, the special conditions of the NWP verification must clearly indicate the party or parties responsible for the implementation and performance of the compensatory mitigation project, and, if required, its long-term management.

(h) Where certain functions and services of waters of the United States are permanently adversely affected, such as the conversion of a forested or scrub-shrub wetland

to a herbaceous wetland in a permanently maintained utility line right-of-way, mitigation may be required to reduce the adverse effects of the project to the minimal level.

24. Safety of Impoundment Structures. To ensure that all impoundment structures are safely designed, the district engineer may require non-Federal applicants to demonstrate that the structures comply with established state dam safety criteria or have been designed by qualified persons. The district engineer may also require documentation that the design has been independently reviewed by similarly qualified persons, and appropriate modifications made to ensure safety.

25. Water Quality. Where States and authorized Tribes, or EPA where applicable, have not previously certified compliance of an NWP with CWA Section 401, individual 401 Water Quality Certification must be obtained or waived (see 33 CFR 330.4(c)). The district engineer or State or Tribe may require additional water quality management measures to ensure that the authorized activity does not result in more than minimal degradation of water quality.

26. Coastal Zone Management. In coastal states where an NWP has not previously received a state coastal zone management consistency concurrence, an individual state coastal zone management consistency concurrence must be obtained, or a presumption of concurrence must occur (see 33 CFR 330.4(d)). The district engineer or a State may require additional measures to ensure that the authorized activity is consistent with state coastal zone management requirements.

27. Regional and Case-By-Case Conditions. The activity must comply with any regional conditions that may have been added by the Division Engineer (see 33 CFR 330.4(e)) and with any case specific conditions added by the Corps or by the state, Indian Tribe, or U.S. EPA in its section 401 Water Quality Certification, or by the state in its Coastal Zone Management Act consistency determination.

28. Use of Multiple Nationwide Permits. The use of more than one NWP for a single and complete project is prohibited, except when the acreage loss of waters of the United States authorized by the NWPs does not exceed the acreage limit of the NWP with the highest specified acreage limit. For example, if a road crossing over tidal waters is constructed under NWP 14, with associated bank stabilization authorized by NWP 13, the maximum acreage loss of waters of the United States for the total project cannot exceed 1/3-acre.

29. Transfer of Nationwide Permit Verifications. If the permittee sells the property associated with a nationwide permit verification, the permittee may transfer the nationwide permit verification to the new owner by submitting a letter to the appropriate Corps district office to validate the transfer. A copy of the nationwide permit verification must be attached to the letter, and the letter must contain the following statement and signature:



“When the structures or work authorized by this nationwide permit are still in existence at the time the property is transferred, the terms and conditions of this nationwide permit, including any special conditions, will continue to be binding on the new owner(s) of the property. To validate the transfer of this nationwide permit and the associated liabilities associated with compliance with its terms and conditions, have the transferee sign and date below.”

---

(Transferee)

---

(Date)

30. Compliance Certification. Each permittee who receives an NWP verification letter from the Corps must provide a signed certification documenting completion of the authorized activity and any required compensatory mitigation. The success of any required permittee-responsible mitigation, including the achievement of ecological performance standards, will be addressed separately by the district engineer. The Corps will provide the permittee the certification document with the NWP verification letter. The certification document will include:

- (a) A statement that the authorized work was done in accordance with the NWP authorization, including any general, regional, or activity-specific conditions;
- (b) A statement that the implementation of any required compensatory mitigation was completed in accordance with the permit conditions. If credits from a mitigation bank or in-lieu fee program are used to satisfy the compensatory mitigation requirements, the certification must include the documentation required by 33 CFR 332.3(1)(3) to confirm that the permittee secured the appropriate number and resource type of credits; and
- (c) The signature of the permittee certifying the completion of the work and mitigation.

31. Pre-Construction Notification. (a) Timing. Where required by the terms of the NWP, the prospective permittee must notify the district engineer by submitting a pre-construction notification (PCN) as early as possible. The district engineer must determine if the PCN is complete within 30 calendar days of the date of receipt and, if the PCN is determined to be incomplete, notify the prospective permittee within that 30 day period to request the additional information necessary to make the PCN complete. The request must specify the information needed to make the PCN complete. As a general rule, district engineers will request additional information necessary to make the PCN complete only once. However, if the prospective permittee does not provide all of the requested information, then the district engineer will notify the prospective permittee that the PCN is still incomplete and the PCN review process will not commence until all of the requested information has been received by the district engineer. The prospective permittee shall not begin the activity until either:

- (1) He or she is notified in writing by the district engineer that the activity may proceed under the NWP with any special conditions imposed by the district or division engineer; or
- (2) 45 calendar days have passed from the district engineer’s receipt of the complete PCN and the prospective permittee has not received written notice from the district or division engineer. However, if the permittee was required to notify the Corps pursuant to general condition 18 that listed species or critical habitat might be affected or in the vicinity of the

project, or to notify the Corps pursuant to general condition 20 that the activity may have the potential to cause effects to historic properties, the permittee cannot begin the activity until receiving written notification from the Corps that there is “no effect” on listed species or “no potential to cause effects” on historic properties, or that any consultation required under Section 7 of the Endangered Species Act (see 33 CFR 330.4(f)) and/or Section 106 of the National Historic Preservation (see 33 CFR 330.4(g)) has been completed. Also, work cannot begin under NWP 21, 49, or 50 until the permittee has received written approval from the Corps. If the proposed activity requires a written waiver to exceed specified limits of an NWP, the permittee may not begin the activity until the district engineer issues the waiver. If the district or division engineer notifies the permittee in writing that an individual permit is required within 45 calendar days of receipt of a complete PCN, the permittee cannot begin the activity until an individual permit has been obtained. Subsequently, the permittee’s right to proceed under the NWP may be modified, suspended, or revoked only in accordance with the procedure set forth in 33 CFR 330.5(d)(2).

(b) Contents of Pre-Construction Notification: The PCN must be in writing and include the following information:

(1) Name, address and telephone numbers of the prospective permittee;

(2) Location of the proposed project;

(3) A description of the proposed project; the project’s purpose; direct and indirect adverse environmental effects the project would cause, including the anticipated amount of loss of water of the United States expected to result from the NWP activity, in acres, linear feet, or other appropriate unit of measure; any other NWP(s), regional general permit(s), or individual permit(s) used or intended to be used to authorize any part of the proposed project or any related activity. The description should be sufficiently detailed to allow the district engineer to determine that the adverse effects of the project will be minimal and to determine the need for compensatory mitigation. Sketches should be provided when necessary to show that the activity complies with the terms of the NWP. (Sketches usually clarify the project and when provided results in a quicker decision. Sketches should contain sufficient detail to provide an illustrative description of the proposed activity (e.g., a conceptual plan), but do not need to be detailed engineering plans);

(4) The PCN must include a delineation of wetlands, other special aquatic sites, and other waters, such as lakes and ponds, and perennial, intermittent, and ephemeral streams, on the project site. Wetland delineations must be prepared in accordance with the current method required by the Corps. The permittee may ask the Corps to delineate the special aquatic sites and other waters on the project site, but there may be a delay if the Corps does the delineation, especially if the project site is large or contains many waters of the United States. Furthermore, the 45 day period will not start until the delineation has been submitted to or completed by the Corps, as appropriate;

(5) If the proposed activity will result in the loss of greater than 1/10-acre of wetlands and a PCN is required, the prospective permittee must submit a statement describing how the mitigation requirement will be satisfied, or explaining why the adverse effects are minimal and why compensatory mitigation should not be required. As an alternative, the prospective permittee may submit a conceptual or detailed mitigation plan.

(6) If any listed species or designated critical habitat might be affected or is in the vicinity of the project, or if the project is located in designated critical habitat, for non-Federal applicants the PCN must include the name(s) of those endangered or threatened species that

might be affected by the proposed work or utilize the designated critical habitat that may be affected by the proposed work. Federal applicants must provide documentation demonstrating compliance with the Endangered Species Act; and

(7) For an activity that may affect a historic property listed on, determined to be eligible for listing on, or potentially eligible for listing on, the National Register of Historic Places, for non-Federal applicants the PCN must state which historic property may be affected by the proposed work or include a vicinity map indicating the location of the historic property. Federal applicants must provide documentation demonstrating compliance with Section 106 of the National Historic Preservation Act.

(c) Form of Pre-Construction Notification: The standard individual permit application form (Form ENG 4345) may be used, but the completed application form must clearly indicate that it is a PCN and must include all of the information required in paragraphs (b)(1) through (7) of this general condition. A letter containing the required information may also be used.

(d) Agency Coordination: (1) The district engineer will consider any comments from Federal and state agencies concerning the proposed activity's compliance with the terms and conditions of the NWP and the need for mitigation to reduce the project's adverse environmental effects to a minimal level.

(2) For all NWP activities that require pre-construction notification and result in the loss of greater than 1/2-acre of waters of the United States, for NWP 21, 29, 39, 40, 42, 43, 44, 50, 51, and 52 activities that require pre-construction notification and will result in the loss of greater than 300 linear feet of intermittent and ephemeral stream bed, and for all NWP 48 activities that require pre-construction notification, the district engineer will immediately provide (e.g., via e-mail, facsimile transmission, overnight mail, or other expeditious manner) a copy of the complete PCN to the appropriate Federal or state offices (U.S. FWS, state natural resource or water quality agency, EPA, State Historic Preservation Officer (SHPO) or Tribal Historic Preservation Office (THPO), and, if appropriate, the NMFS). With the exception of NWP 37, these agencies will have 10 calendar days from the date the material is transmitted to telephone or fax the district engineer notice that they intend to provide substantive, site-specific comments. The comments must explain why the agency believes the adverse effects will be more than minimal. If so contacted by an agency, the district engineer will wait an additional 15 calendar days before making a decision on the pre-construction notification. The district engineer will fully consider agency comments received within the specified time frame concerning the proposed activity's compliance with the terms and conditions of the NWPs, including the need for mitigation to ensure the net adverse environmental effects to the aquatic environment of the proposed activity are minimal. The district engineer will provide no response to the resource agency, except as provided below. The district engineer will indicate in the administrative record associated with each pre-construction notification that the resource agencies' concerns were considered. For NWP 37, the emergency watershed protection and rehabilitation activity may proceed immediately in cases where there is an unacceptable hazard to life or a significant loss of property or economic hardship will occur. The district engineer will consider any comments received to decide whether the NWP 37 authorization should be modified, suspended, or revoked in accordance with the procedures at 33 CFR 330.5.

(3) In cases of where the prospective permittee is not a Federal agency, the district engineer will provide a response to NMFS within 30 calendar days of receipt of any Essential Fish Habitat conservation recommendations, as required by Section 305(b)(4)(B) of the Magnuson-Stevens Fishery Conservation and Management Act.

(4) Applicants are encouraged to provide the Corps with either electronic files or multiple copies of pre-construction notifications to expedite agency coordination.

### **District Engineer's Decision**

1. In reviewing the PCN for the proposed activity, the district engineer will determine whether the activity authorized by the NWP will result in more than minimal individual or cumulative adverse environmental effects or may be contrary to the public interest. For a linear project, this determination will include an evaluation of the individual crossings to determine whether they individually satisfy the terms and conditions of the NWP(s), as well as the cumulative effects caused by all of the crossings authorized by NWP. If an applicant requests a waiver of the 300 linear foot limit on impacts to intermittent or ephemeral streams or of an otherwise applicable limit, as provided for in NWPs 13, 21, 29, 36, 39, 40, 42, 43, 44, 50, 51 or 52, the district engineer will only grant the waiver upon a written determination that the NWP activity will result in minimal adverse effects. When making minimal effects determinations the district engineer will consider the direct and indirect effects caused by the NWP activity. The district engineer will also consider site specific factors, such as the environmental setting in the vicinity of the NWP activity, the type of resource that will be affected by the NWP activity, the functions provided by the aquatic resources that will be affected by the NWP activity, the degree or magnitude to which the aquatic resources perform those functions, the extent that aquatic resource functions will be lost as a result of the NWP activity (e.g., partial or complete loss), the duration of the adverse effects (temporary or permanent), the importance of the aquatic resource functions to the region (e.g., watershed or ecoregion), and mitigation required by the district engineer. If an appropriate functional assessment method is available and practicable to use, that assessment method may be used by the district engineer to assist in the minimal adverse effects determination. The district engineer may add case-specific special conditions to the NWP authorization to address site-specific environmental concerns.
2. If the proposed activity requires a PCN and will result in a loss of greater than 1/10- acre of wetlands, the prospective permittee should submit a mitigation proposal with the PCN. Applicants may also propose compensatory mitigation for projects with smaller impacts. The district engineer will consider any proposed compensatory mitigation the applicant has included in the proposal in determining whether the net adverse environmental effects to the aquatic environment of the proposed activity are minimal. The compensatory mitigation proposal may be either conceptual or detailed. If the district engineer determines that the activity complies with the terms and conditions of the NWP and that the adverse effects on the aquatic environment are minimal, after considering mitigation, the district engineer will notify the permittee and include any activity-specific conditions in the NWP verification the district engineer deems necessary. Conditions for compensatory mitigation requirements must comply with the appropriate provisions at 33 CFR 332.3(k). The district engineer must approve the final mitigation plan before the permittee commences work in waters of the United States, unless the district engineer determines that prior approval of the final mitigation plan is not practicable or not necessary to ensure timely completion of the required compensatory mitigation. If the prospective permittee elects to submit a compensatory mitigation plan with the PCN, the district engineer will expeditiously review the proposed compensatory mitigation plan. The district engineer must review the proposed compensatory

mitigation plan within 45 calendar days of receiving a complete PCN and determine whether the proposed mitigation would ensure no more than minimal adverse effects on the aquatic environment. If the net adverse effects of the project on the aquatic environment (after consideration of the compensatory mitigation proposal) are determined by the district engineer to be minimal, the district engineer will provide a timely written response to the applicant. The response will state that the project can proceed under the terms and conditions of the NWP, including any activity-specific conditions added to the NWP authorization by the district engineer.

3. If the district engineer determines that the adverse effects of the proposed work are more than minimal, then the district engineer will notify the applicant either: (a) that the project does not qualify for authorization under the NWP and instruct the applicant on the procedures to seek authorization under an individual permit; (b) that the project is authorized under the NWP subject to the applicant's submission of a mitigation plan that would reduce the adverse effects on the aquatic environment to the minimal level; or (c) that the project is authorized under the NWP with specific modifications or conditions. Where the district engineer determines that mitigation is required to ensure no more than minimal adverse effects occur to the aquatic environment, the activity will be authorized within the 45-day PCN period, with activity-specific conditions that state the mitigation requirements. The authorization will include the necessary conceptual or detailed mitigation or a requirement that the applicant submit a mitigation plan that would reduce the adverse effects on the aquatic environment to the minimal level. When mitigation is required, no work in waters of the United States may occur until the district engineer has approved a specific mitigation plan or has determined that prior approval of a final mitigation plan is not practicable or not necessary to ensure timely completion of the required compensatory mitigation.

### **Further Information**

- District Engineers have authority to determine if an activity complies with the terms and conditions of an NWP.
- NWPs do not obviate the need to obtain other federal, state, or local permits, approvals, or authorizations required by law.
- NWPs do not grant any property rights or exclusive privileges.
- NWPs do not authorize any injury to the property or rights of others.
- NWPs do not authorize interference with any existing or proposed Federal project.

### **Definitions**

**Best management practices (BMPs):** Policies, practices, procedures, or structures implemented to mitigate the adverse environmental effects on surface water quality resulting from development. BMPs are categorized as structural or non-structural.

**Compensatory mitigation:** The restoration (re-establishment or rehabilitation), establishment (creation), enhancement, and/or in certain circumstances preservation of aquatic resources for the purposes of offsetting unavoidable adverse impacts which remain after all appropriate and practicable avoidance and minimization has been achieved.

**Currently serviceable:** Useable as is or with some maintenance, but not so degraded as to essentially require reconstruction.

**Direct effects:** Effects that are caused by the activity and occur at the same time and place.

**Discharge:** The term “discharge” means any discharge of dredged or fill material. **Enhancement:** The manipulation of the physical, chemical, or biological characteristics of an aquatic resource to heighten, intensify, or improve a specific aquatic resource function(s). Enhancement results in the gain of selected aquatic resource function(s), but may also lead to a decline in other aquatic resource function(s). Enhancement does not result in a gain in aquatic resource area.

**Ephemeral stream:** An ephemeral stream has flowing water only during, and for a short duration after, precipitation events in a typical year. Ephemeral stream beds are located above the water table year-round. Groundwater is not a source of water for the stream. Runoff from rainfall is the primary source of water for stream flow.

**Establishment (creation):** The manipulation of the physical, chemical, or biological characteristics present to develop an aquatic resource that did not previously exist at an upland site. Establishment results in a gain in aquatic resource area.

**High Tide Line:** The line of intersection of the land with the water’s surface at the maximum height reached by a rising tide. The high tide line may be determined, in the absence of actual data, by a line of oil or scum along shore objects, a more or less continuous deposit of fine shell or debris on the foreshore or berm, other physical markings or characteristics, vegetation lines, tidal gages, or other suitable means that delineate the general height reached by a rising tide. The line encompasses spring high tides and other high tides that occur with periodic frequency but does not include storm surges in which there is a departure from the normal or predicted reach of the tide due to the piling up of water against a coast by strong winds such as those accompanying a hurricane or other intense storm.

**Historic Property:** Any prehistoric or historic district, site (including archaeological site), building, structure, or other object included in, or eligible for inclusion in, the National Register of Historic Places maintained by the Secretary of the Interior. This term includes artifacts, records, and remains that are related to and located within such properties. The term includes properties of traditional religious and cultural importance to an Indian tribe or Native Hawaiian organization and that meet the National Register criteria (36 CFR part 60).

**Independent utility:** A test to determine what constitutes a single and complete non-linear project in the Corps regulatory program. A project is considered to have independent utility if it would be constructed absent the construction of other projects in the project area. Portions of a multi-phase project that depend upon other phases of the project do not have independent utility. Phases of a project that would be constructed even if the other phases were not built can be considered as separate single and complete projects with independent utility.

**Indirect effects:** Effects that are caused by the activity and are later in time or farther removed in distance, but are still reasonably foreseeable.

**Intermittent stream:** An intermittent stream has flowing water during certain times of the year, when groundwater provides water for stream flow. During dry periods, intermittent streams may not have flowing water. Runoff from rainfall is a supplemental source of water for stream flow.

**Loss of waters of the United States:** Waters of the United States that are permanently adversely affected by filling, flooding, excavation, or drainage because of the regulated activity. Permanent adverse effects include permanent discharges of dredged or fill material that change an aquatic area to dry land, increase the bottom elevation of a waterbody, or change the use of a waterbody. The acreage of loss of waters of the United States is a threshold measurement of the impact to

jurisdictional waters for determining whether a project may qualify for an NWP; it is not a net threshold that is calculated after considering compensatory mitigation that may be used to offset losses of aquatic functions and services. The loss of stream bed includes the linear feet of stream bed that is filled or excavated. Waters of the United States temporarily filled, flooded, excavated, or drained, but restored to pre-construction contours and elevations after construction, are not included in the measurement of loss of waters of the United States. Impacts resulting from activities eligible for exemptions under Section 404(f) of the Clean Water Act are not considered when calculating the loss of waters of the United States.

**Non-tidal wetland:** A non-tidal wetland is a wetland that is not subject to the ebb and flow of tidal waters. The definition of a wetland can be found at 33 CFR 328.3(b). Non-tidal wetlands contiguous to tidal waters are located landward of the high tide line (i.e., spring high tide line).

**Open water:** For purposes of the NWPs, an open water is any area that in a year with normal patterns of precipitation has water flowing or standing above ground to the extent that an ordinary high water mark can be determined. Aquatic vegetation within the area of standing or flowing water is either non-emergent, sparse, or absent. Vegetated shallows are considered to be open waters. Examples of “open waters” include rivers, streams, lakes, and ponds.

**Ordinary High Water Mark:** An ordinary high water mark is a line on the shore established by the fluctuations of water and indicated by physical characteristics, or by other appropriate means that consider the characteristics of the surrounding areas (see 33 CFR 328.3(e)).

**Perennial stream:** A perennial stream has flowing water year-round during a typical year. The water table is located above the stream bed for most of the year. Groundwater is the primary source of water for stream flow. Runoff from rainfall is a supplemental source of water for stream flow.

**Practicable:** Available and capable of being done after taking into consideration cost, existing technology, and logistics in light of overall project purposes.

**Pre-construction notification:** A request submitted by the project proponent to the Corps for confirmation that a particular activity is authorized by nationwide permit. The request may be a permit application, letter, or similar document that includes information about the proposed work and its anticipated environmental effects. Pre-construction notification may be required by the terms and conditions of a nationwide permit, or by regional conditions. A pre-construction notification may be voluntarily submitted in cases where pre-construction notification is not required and the project proponent wants confirmation that the activity is authorized by nationwide permit.

**Preservation:** The removal of a threat to, or preventing the decline of, aquatic resources by an action in or near those aquatic resources. This term includes activities commonly associated with the protection and maintenance of aquatic resources through the implementation of appropriate legal and physical mechanisms. Preservation does not result in a gain of aquatic resource area or functions.

**Re-establishment:** The manipulation of the physical, chemical, or biological characteristics of a site with the goal of returning natural/historic functions to a former aquatic resource. Re-establishment results in rebuilding a former aquatic resource and results in a gain in aquatic resource area and functions.

**Rehabilitation:** The manipulation of the physical, chemical, or biological characteristics of a site with the goal of repairing natural/historic functions to a degraded aquatic resource.

Rehabilitation results in a gain in aquatic resource function, but does not result in a gain in aquatic resource area.

**Restoration:** The manipulation of the physical, chemical, or biological characteristics of a site with the goal of returning natural/historic functions to a former or degraded aquatic resource. For the purpose of tracking net gains in aquatic resource area, restoration is divided into two categories: re-establishment and rehabilitation.

**Riffle and pool complex:** Riffle and pool complexes are special aquatic sites under the 404(b)(1) Guidelines. Riffle and pool complexes sometimes characterize steep gradient sections of streams. Such stream sections are recognizable by their hydraulic characteristics. The rapid movement of water over a coarse substrate in riffles results in a rough flow, a turbulent surface, and high dissolved oxygen levels in the water. Pools are deeper areas associated with riffles. A slower stream velocity, a streaming flow, a smooth surface, and a finer substrate characterize pools.

**Riparian areas:** Riparian areas are lands adjacent to streams, lakes, and estuarine-marine shorelines. Riparian areas are transitional between terrestrial and aquatic ecosystems, through which surface and subsurface hydrology connects riverine, lacustrine, estuarine, and marine waters with their adjacent wetlands, non-wetland waters, or uplands. Riparian areas provide a variety of ecological functions and services and help improve or maintain local water quality. (See general condition 23.)

**Shellfish seeding:** The placement of shellfish seed and/or suitable substrate to increase shellfish production. Shellfish seed consists of immature individual shellfish or individual shellfish attached to shells or shell fragments (i.e., spat on shell). Suitable substrate may consist of shellfish shells, shell fragments, or other appropriate materials placed into waters for shellfish habitat.

**Single and complete linear project:** A linear project is a project constructed for the purpose of getting people, goods, or services from a point of origin to a terminal point, which often involves multiple crossings of one or more waterbodies at separate and distant locations. The term “single and complete project” is defined as that portion of the total linear project proposed or accomplished by one owner/developer or partnership or other association of owners/developers that includes all crossings of a single water of the United States (i.e., a single waterbody) at a specific location. For linear projects crossing a single or multiple waterbodies several times at separate and distant locations, each crossing is considered a single and complete project for purposes of NWP authorization. However, individual channels in a braided stream or river, or individual arms of a large, irregularly shaped wetland or lake, etc., are not separate waterbodies, and crossings of such features cannot be considered separately.

**Single and complete non-linear project:** For non-linear projects, the term “single and complete project” is defined at 33 CFR 330.2(i) as the total project proposed or accomplished by one owner/developer or partnership or other association of owners/developers. A single and complete non-linear project must have independent utility (see definition of “independent utility”). Single and complete non-linear projects may not be “piecemealed” to avoid the limits in an NWP authorization.

**Stormwater management:** Stormwater management is the mechanism for controlling stormwater runoff for the purposes of reducing downstream erosion, water quality degradation, and flooding and mitigating the adverse effects of changes in land use on the aquatic environment.



**Stormwater management facilities:** Stormwater management facilities are those facilities, including but not limited to, stormwater retention and detention ponds and best management practices, which retain water for a period of time to control runoff and/or improve the quality (i.e., by reducing the concentration of nutrients, sediments, hazardous substances and other pollutants) of stormwater runoff.

**Stream bed:** The substrate of the stream channel between the ordinary high water marks. The substrate may be bedrock or inorganic particles that range in size from clay to boulders. Wetlands contiguous to the stream bed, but outside of the ordinary high water marks, are not considered part of the stream bed.

**Stream channelization:** The manipulation of a stream's course, condition, capacity, or location that causes more than minimal interruption of normal stream processes. A channelized stream remains a water of the United States.

**Structure:** An object that is arranged in a definite pattern of organization. Examples of structures include, without limitation, any pier, boat dock, boat ramp, wharf, dolphin, weir, boom, breakwater, bulkhead, revetment, riprap, jetty, artificial island, artificial reef, permanent mooring structure, power transmission line, permanently moored floating vessel, piling, aid to navigation, or any other manmade obstacle or obstruction.

**Tidal wetland:** A tidal wetland is a wetland (i.e., water of the United States) that is inundated by tidal waters. The definitions of a wetland and tidal waters can be found at 33 CFR 328.3(b) and 33 CFR 328.3(f), respectively. Tidal waters rise and fall in a predictable and measurable rhythm or cycle due to the gravitational pulls of the moon and sun. Tidal waters end where the rise and fall of the water surface can no longer be practically measured in a predictable rhythm due to masking by other waters, wind, or other effects. Tidal wetlands are located channelward of the high tide line, which is defined at 33 CFR 328.3(d).

**Vegetated shallows:** Vegetated shallows are special aquatic sites under the 404(b)(1) Guidelines. They are areas that are permanently inundated and under normal circumstances have rooted aquatic vegetation, such as seagrasses in marine and estuarine systems and a variety of vascular rooted plants in freshwater systems.

**Waterbody:** For purposes of the NWP, a waterbody is a jurisdictional water of the United States. If a jurisdictional wetland is adjacent – meaning bordering, contiguous, or neighboring – to a waterbody determined to be a water of the United States under 33 CFR 328.3(a)(1)-(6), that waterbody and its adjacent wetlands are considered together as a single aquatic unit (see 33 CFR 328.4(c)(2)). Examples of “waterbodies” include streams, rivers, lakes, ponds, and wetlands.



**ENERGY AND ENVIRONMENTAL PROTECTION CABINET**

DEPARTMENT FOR ENVIRONMENTAL PROTECTION

DIVISION OF WATER

200 FAIR OAKS LANE

FRANKFORT, KENTUCKY 40601

[www.kentucky.gov](http://www.kentucky.gov)

## **General Certification--Nationwide Permit # 14 Linear Transportation Projects**

This General Certification is issued March 19, 2012, in conformity with the requirements of Section 401 of the Clean Water Act of 1977, as amended (33 U.S.C. §1341), as well as Kentucky Statute KRS 224.16-050.

For this and all nationwide permits, the definition of surface water is as per 401 KAR 10:001 Chapter 10, Section 1(80): Surface Waters means those waters having well-defined banks and beds, either constantly or intermittently flowing; lakes and impounded waters; marshes and wetlands; and any subterranean waters flowing in well-defined channels and having a demonstrable hydrologic connection with the surface. Lagoons used for waste treatment and effluent ditches that are situated on property owned, leased, or under valid easement by a permitted discharger are not considered to be surface waters of the commonwealth.

Agricultural operations, as defined by KRS 224.71-100(1) conducting activities pursuant to KRS 224.71-100 (3), (4), (5), (6), or 10 are deemed to have certification if they are implementing an Agriculture Water Quality Plan pursuant to KRS 224.71-145.

For all other operations, the Commonwealth of Kentucky hereby certifies under Section 401 of the Clean Water Act (CWA) that it has reasonable assurances that applicable water quality standards under Kentucky Administrative Regulations Title 401, Chapter 10, established pursuant to Sections 301, 302, 304, 306 and 307 of the CWA, will not be violated for the activity covered under NATIONWIDE PERMIT 14, namely Linear Transportation Projects, provided that the following conditions are met:

1. The activity will not occur within surface waters of the Commonwealth identified by the Kentucky Division of Water as Outstanding State or National Resource Water, Cold Water Aquatic Habitat, or Exceptional Waters.
2. The activity will not occur within surface waters of the Commonwealth identified as perpetually-protected (e.g. deed restriction, conservation easement) mitigation sites.
3. The activity will impact less than 1/2 acre of wetland/marsh.
4. The activity will impact less than 300 linear feet of surface waters of the Commonwealth. Stream realignment greater than 100 feet is not covered under this general water quality certification.

**General Certification--Nationwide Permit # 14**  
**Linear Transportation Projects**  
**Page 2**

5. For a single and complete linear transportation project, the cumulative length of impacts less than 300 linear feet of surface waters within each Hydrologic Unit Code (HUC) 14 watershed will not exceed 500 linear feet.
6. Stream impacts covered under this General Water Quality Certification and undertaken by those persons defined as an agricultural operation under the Agricultural Water Quality Act must be completed in compliance with the Kentucky Agricultural Water Quality Plan (KWQP).
7. The Kentucky Division of Water may require submission of a formal application for an individual certification for any project if the project has been determined to likely have a significant adverse effect upon water quality or degrade the waters of the Commonwealth so that existing uses of the water body or downstream waters are precluded.
8. Activities that do not meet the conditions of this General Water Quality Certification require an Individual Section 401 Water Quality Certification.
9. Activities qualifying for coverage under this General Water Quality Certification are subject to the following conditions:
  - Erosion and sedimentation pollution control plans and Best Management Practices must be designed, installed, and maintained in effective operating condition at all times during construction activities so that violations of state water quality standards do not occur (401 KAR 10:031 Section 2 and KRS 224.70-100).
  - Sediment and erosion control measures, such as check-dams constructed of any material, silt fencing, hay bales, etc., shall not be placed within surface waters of the Commonwealth, either temporarily or permanently, without prior approval by the Kentucky Division of Water's Water Quality Certification Section. If placement of sediment and erosion control measures in surface waters is unavoidable, design and placement of temporary erosion control measures shall not be conducted in such a manner that may result in instability of streams that are adjacent to, upstream, or downstream of the structures. All sediment and erosion control devices shall be removed and the natural grade restored within the completion timeline of the activities.
  - Measures shall be taken to prevent or control spills of fuels, lubricants, or other toxic materials used in construction from entering the watercourse.
  - Removal of riparian vegetation in the utility line right-of-way shall be limited to that necessary for equipment access.
  - To the maximum extent practicable, all in-stream work under this certification shall be performed under low-flow conditions.

**General Certification--Nationwide Permit # 14**  
**Linear Transportation Projects**  
**Page 2**

- Heavy equipment, e.g. bulldozers, backhoes, draglines, etc., if required for this project, should not be used or operated within the stream channel. In those instances in which such in-stream work is unavoidable, then it shall be performed in such a manner and duration as to minimize turbidity and disturbance to substrates and bank or riparian vegetation.
- Any fill shall be of such composition that it will not adversely affect the biological, chemical, or physical properties of the receiving waters and/or cause violations of water quality standards. If rip-rap is utilized, it should be of such weight and size that bank stress or slump conditions will not be created because of its placement.
- If there are water supply intakes located downstream that may be affected by increased turbidity and suspended solids, the permittee shall notify the operator when such work will be done.
- Should evidence of stream pollution or jurisdictional wetland impairment and/or violations of water quality standards occur as a result of this activity (either from a spill or other forms of water pollution), the KDOW shall be notified immediately by calling (800) 928-2380.

Non-compliance with the conditions of this general certification or violation of Kentucky state water quality standards may result in civil penalties.

## APPENDIX D

### Utility Company Contact List

## Utility Companies Contact List

Kentucky Utilities Company  
Kevin Montgomery  
Transmission Project Coordinator  
198 West Broadway  
Danville, KY 40422  
859-936-3219

Salt River Electric  
Gary Pile  
111 West Brashear Ave.  
Bardstown, Ky 40004  
502-348-3931

AT&T  
Mike Deiderich  
7555 E. Pleasant Valley Rd. - Suite 140  
Independence. Oh. 44131  
216-750-0135

Louisville Gas & Electric  
Greg Geiser  
820 W. Broadway,  
P.O. Box 32020  
Louisville, KY 40232-2020

City of Bardstown  
Jessica Filiatreau - Water and Sewer  
220 N. Fifth Street  
Bardstown, KY 40004  
502-348-5947

City of Bardstown  
Jeff Mills – Electric / CATV  
220 N. Fifth Street  
Bardstown, KY 40004  
502-348-5947

RJ Corman  
Debbie Hawley  
101 RJ Corman Drive  
Nicholasville, KY 40356  
859-881-7521

## APPENDIX E

### Traffic Signal Items

## Traffic Signal Requirements

The DBT shall be responsible for developing traffic signal plans and installing traffic signal equipment at the following intersections:

### Intersection List:

KY 245 @ Filiatreau/Culpepper	MP 0.232
KY 245 @ Spencer Mattingly/Twin Cinema Ln	MP 1.113
KY 245 @ US 62	MP 2.334

The plans shall be prepared by a Consultant pre-qualified by KYTC for Electrical Engineering Traffic Signal Services and should be in compliance with KYTC Division of Traffic Operations practices. All plans shall be done in Microstation format. Plans shall meet current CADD standards and shall be developed in accordance with the current edition of the Kentucky Standards and Specifications for Road and Bridge Construction, the Division of Traffic Operations' Standard Detail Sheets, the National Electrical Code, and the National Electrical Safety Code. The plans shall be submitted to the Central Office Division of Traffic Operations for review and approval before any construction occurs. The Division's review of submittals shall take no longer than 14 working days. Further submittals (with individual 14 working day review periods) may be required until all issues are addressed and documentation is approved.

At a minimum, the traffic signal plans shall include the following items for each intersection:

- Traffic Signal Layout
- Layout Notes
- Loop Schedule
- Wiring Schedule
- Signal Heads Chart which includes attachments heights and pole base moments
- Estimate of Quantities
- Bit Item Notes
- All Applicable KYTC Division of Traffic Operations Standard Detail Sheets (available on the Division of Traffic Operations website: <http://transportation.ky.gov/Traffic-Operations/Pages/Design-Services-Branch-Standards-and-Tools.aspx> )
- Pole and base calculations in KYTC provided Web app SALSA. See website: <http://salsa.bridgeweb.us/> This Website will require a password from Division of Traffic Operations.
- Antenna including radio/wiring if needed

KYTC will provide the following items, as required, for installation at each intersection:

- 170 Traffic Signal Controller and Model 332 or 336 Cabinet
- Model 242 Ped Isolator
- Model 222 Loop Detectors
- Load Switches
- Vehicular and Pedestrian Traffic Signal Housings with LED Modules
- Signal System Equipment
- Steel Strain Poles(28' to 40' poles are available to be supplied by KYTC)
- And all other items listed on the excel spreadsheet:



<http://transportation.ky.gov/Traffic-Operations/Documents/Project%20Install%20Items02-18-2013.xls>

The DBT shall be responsible for picking up items supplied by KYTC from the Frankfort pole yard and delivering these items to the site. The DBT shall contact Frankfort pole yard personnel (502-564-3820) and arrange to pick up install items a minimum of two (2) working days prior to arrival. Failure to provide pole yard personnel this advance notice could result in long delays or refusal to distribute equipment upon arrival.

Construction shall be performed by an electrical contractor prequalified by KYTC for traffic signal installations. Installation shall be in compliance with the plans, Kentucky Standard Specifications for Road and Bridge Construction, Standard Detail Sheets, National Electrical Code, Manual on Uniform Traffic Control Devices and the local utility company serving the installations. Included in the traffic signal installations shall be the removal of items not to re-used. Removed control equipment and signal heads shall be returned to the Department of Highways as directed by Engineer. All other equipment and material shall be disposed of off the project.

The Division of Traffic Operations shall conduct an inspection of all signals installed on this project. The Division shall prepare a list of required corrective work and send it to the applicable personnel. Additional inspections of corrective work may be required until identified issues have been addressed.

Please be advised that proper clearance between the existing electrical transmission lines and any signal modifications must be maintained. KYTC expects the DBT to prepare plans such that the electrical transmission lines do not need to be relocated in order to accommodate any traffic signal modifications.

## APPENDIX F

### Employment Wage, Record, and Insurance Requirements

General Decision Number: KY130100 09/27/2013 KY100

Superseded General Decision Number: KY20120125

State: Kentucky

Construction Type: Highway

Counties: Anderson, Bath, Bourbon, Boyd, Boyle, Bracken, Breckinridge, Bullitt, Carroll, Carter, Clark, Elliott, Fayette, Fleming, Franklin, Gallatin, Grant, Grayson, Greenup, Hardin, Harrison, Henry, Jefferson, Jessamine, Larue, Lewis, Madison, Marion, Mason, Meade, Mercer, Montgomery, Nelson, Nicholas, Oldham, Owen, Robertson, Rowan, Scott, Shelby, Spencer, Trimble, Washington and Woodford Counties in Kentucky.

HIGHWAY CONSTRUCTION PROJECTS (excluding tunnels, building structures in rest area projects & railroad construction; bascule, suspension & spandrel arch bridges designed for commercial navigation, bridges involving marine construction; and other major bridges).

Modification Number	Publication Date
0	01/04/2013
1	01/11/2013
2	02/22/2013
3	04/26/2013
4	05/31/2013
5	06/07/2013
6	06/14/2013
7	06/21/2013
8	06/28/2013
9	07/05/2013
10	07/19/2013
11	08/30/2013
12	09/20/2013
13	09/27/2013

BRIN0004-003 06/01/2011

BRECKENRIDGE COUNTY

	Rates	Fringes
BRICKLAYER.....	\$ 24.11	10.07

BRKY0001-005 06/01/2013

BULLITT, CARROLL, GRAYSON, HARDIN, HENRY, JEFFERSON, LARUE, MARION, MEADE, NELSON, OLDHAM, SHELBY, SPENCER, & TRIMBLE COUNTIES:

	Rates	Fringes
BRICKLAYER.....	\$ 24.82	10.71

BRKY0002-006 06/01/2011

## BRACKEN, GALLATIN, GRANT, MASON &amp; ROBERTSON COUNTIES:

	Rates	Fringes
BRICKLAYER.....	\$ 26.57	10.26

-----  
BRKY0007-004 06/01/2011

## BOYD, CARTER, ELLIOT, FLEMING, GREENUP, LEWIS &amp; ROWAN COUNTIES:

	Rates	Fringes
BRICKLAYER.....	\$ 28.29	16.80

-----  
BRKY0017-004 06/01/2009ANDERSON, BATH, BOURBON, BOYLE, CLARK, FAYETTE, FRANKLIN,  
HARRISON, JESSAMINE, MADISON, MERCER, MONTGOMERY, NICHOLAS,  
OWEN, SCOTT, WASHINGTON & WOODFORD COUNTIES:

	Rates	Fringes
BRICKLAYER.....	\$ 24.11	9.97

-----  
CARP0064-001 04/01/2013

	Rates	Fringes
CARPENTER.....	\$ 26.90	14.46
Diver.....	\$ 40.73	14.46
PILEDRIVERMAN.....	\$ 27.15	14.46

-----  
ELEC0212-008 06/03/2013

## BRACKEN, GALLATIN and GRANT COUNTIES

	Rates	Fringes
ELECTRICIAN.....	\$ 26.35	16.09

-----  
\* ELEC0212-014 07/01/2013

## BRACKEN, GALLATIN &amp; GRANT COUNTIES:

	Rates	Fringes
Sound & Communication Technician.....	\$ 22.50	9.51

-----  
ELEC0317-012 05/30/2012

## BOYD, CARTER, ELLIOT &amp; ROWAN COUNTIES:

	Rates	Fringes
Electricians:		
Cable Splicer.....	\$ 32.68	18.13
Electrician.....	\$ 32.22	20.09

-----  
 ELEC0369-007 05/29/2013

ANDERSON, BATH, BOURBON, BOYLE, BRECKINRIDGE, BULLITT, CARROLL,  
 CLARK, FAYETTE, FRAONKLIN, GRAYSON, HARDIN, HARRISON, HENRY,  
 JEFFERSON, JESSAMINE, LARUE, MADISON, MARION, MEADE, MERCER,  
 MONTGOMERY, NELSON, NICHOLAS, OLDHAM, OWEN, ROBERTSON, SCOTT,  
 SHELBY, SPENCER, TRIMBLE, WASHINGTON, & WOODFORD COUNTIES:

	Rates	Fringes
ELECTRICIAN.....	\$ 29.48	14.37

-----  
 ELEC0575-002 12/31/2012

FLEMING, GREENUP, LEWIS & MASON COUNTIES:

	Rates	Fringes
ELECTRICIAN.....	\$ 31.20	13.55

-----  
 ENGI0181-018 07/01/2013

	Rates	Fringes
Operating Engineer:		
GROUP 1.....	\$ 28.00	13.90
GROUP 2.....	\$ 25.45	13.90
GROUP 3.....	\$ 25.85	13.90
GROUP 4.....	\$ 25.17	13.90

#### OPERATING ENGINEER CLASSIFICATIONS

GROUP 1 - A-Frame Winch Truck; Auto Patrol; Backfiller;  
 Batch Plant; Bituminous Paver; Bituminous Transfer  
 Machine; Boom Cat; Bulldozer; Mechanic; Cableway; Carry-All  
 Scoop; Carry Deck Crane; Central Compressor Plant; Cherry  
 Picker; Clamshell; Concrete Mixer (21 cu. ft. or Over);  
 Concrete Paver; Truck-Mounted Concrete Pump; Core Drill;  
 Crane; Crusher Plant; Derrick; Derrick Boat; Ditching &  
 Trenching Machine; Dragline; Dredge Operator; Dredge  
 Engineer; Elevating Grader & Loaders; Grade-All; Gurries;  
 Heavy Equipment Robotics Operator/Mechanic; High Lift;  
 Hoe-Type Machine; Hoist (Two or More Drums); Hoisting  
 Engine (Two or More Drums); Horizontal Directional Drill  
 Operator; Hydrocrane; Hyster; KeCal Loader; LeTourneau;  
 Locomotive; Mechanic; Mechanically Operated Laser Screed;  
 Mechanic Welder; Mucking Machine; Motor Scraper; Orangepeel  
 Bucket; Overhead Crane; Piledriver; Power Blade; Pumpcrete;  
 Push Dozer; Rock Spreader, attached to equipment; Rotary  
 Drill; Roller (Bituminous); Rough Terrain Crane; Scarifier;  
 Scoopmobile; Shovel; Side Boom; Subgrader; Tailboom;  
 Telescoping Type Forklift; Tow or Push Boat; Tower Crane  
 (French, German & other types); Tractor Shovel; Truck  
 Crane; Tunnel Mining Machines, including Moles, Shields or  
 similar types of Tunnel Mining Equipment

GROUP 2 - Air Compressor (Over 900 cu. ft. per min.);  
 Bituminous Mixer; Boom Type Tamping Machine; Bull Float;

Concrete Mixer (Under 21 cu. ft.); Dredge Engineer;  
 Electric Vibrator; Compactor/Self-Propelled Compactor;  
 Elevator (One Drum or Buck Hoist); Elevator (When used to  
 Hoist Building Material); Finish Machine; Firemen & Hoist  
 (One Drum); Flexplane; Forklift (Regardless of Lift  
 Height); Form Grader; Joint Sealing Machine; Outboard Motor  
 Boat; Power Sweeper (Riding Type); Roller (Rock); Ross  
 Carrier; Skid Mounted or Trailer Mounted Concrete Pump; Skid  
 Steer Machine with all Attachments; Switchman or Brakeman;  
 Throttle Valve Person; Tractair & Road Widening Trencher;  
 Tractor (50 H.P. or Over); Truck Crane Oiler; Tugger;  
 Welding Machine; Well Points; & Whirley Oiler

GROUP 3 - All Off Road Material Handling Equipment,  
 including Articulating Dump Trucks; Greaser on Grease  
 Facilities servicing Heavy Equipment

GROUP 4 - Bituminous Distributor; Burlap & Curing Machine;  
 Cement Gun; Concrete Saw; Conveyor; Deckhand Oiler; Grout  
 Pump; Hydraulic Post Driver; Hydro Seeder; Mud Jack; Oiler;  
 Paving Joint Machine; Power Form Handling Equipment; Pump;  
 Roller (Earth); Steerman; Tamping Machine; Tractor (Under  
 50 H.P.); & Vibrator

CRANES - with booms 150 ft. & Over (Including JIB), and where  
 the length of the boom in combination with the length of  
 the piling leads equals or exceeds 150 ft. - \$1.00 over  
 Group 1 rate

EMPLOYEES ASSIGNED TO WORK BELOW GROUND LEVEL ARE TO BE PAID  
 10%  
 ABOVE BASIC WAGE RATE. THIS DOES NOT APPLY TO OPEN CUT WORK.

-----  
 IRON0044-009 06/01/2013

BRACKEN, GALLATIN, GRANT, HARRISON, ROBERTSON,  
 BOURBON (Northern third, including Townships of Jackson,  
 Millersburg, Ruddel Mills & Shawhan);  
 CARROLL (Eastern third, including the Township of Ghent);  
 FLEMING (Western part, excluding Townships of Beechburg, Colfax,  
 Elizaville, Flemingsburg, Flemingsburg Junction, Foxport,  
 Grange City, Hillsboro, Hilltop, Mount Carmel, Muses Mills,  
 Nepton, Pecksridge, Plummers Landing, Plummers Mill, Poplar  
 Plains, Ringos Mills, Tilton & Wallingford);  
 MASON (Western two-thirds, including Townships of Dover,  
 Lewisburg, Mays Lick, Maysville, Minerva, Moranburg,  
 Murphysville, Ripley, Sardis, Shannon, South Ripley &  
 Washington);  
 NICHOLAS (Townships of Barefoot, Barterville, Carlisle,  
 Ellisville, Headquarters, Henryville, Morningglory, Myers &  
 Oakland Mills);  
 OWEN (Townships of Beechwood, Bromley, Fairbanks, Holbrook,  
 Jonesville, Long Ridge, Lusby's Mill, New, New Columbus, New  
 Liberty, Owenton, Poplar Grove, Rockdale, Sanders, Teresita &  
 Wheatley);  
 SCOTT (Northern two-thirds, including Townships of Biddle,  
 Davis, Delaplain, Elmville, Longlick, Muddy Ford, Oxford,  
 Rogers Gap, Sadieville, Skinnersburg & Stonewall)

	Rates	Fringes
IRONWORKER		
Fence Erector.....	\$ 22.50	18.40
Structural.....	\$ 24.80	18.40

-----  
IRON0070-006 06/01/2013

ANDERSON, BOYLE, BRECKINRIDGE, BULLITT, FAYETTE, FRANKLIN,  
GRAYSON, HARDIN, HENRY, JEFFERSON, JESSAMINE, LARUE, MADISON,  
MARION, MEADE, MERCER, NELSON, OLDHAM, SHELBY, SPENCER,  
TRIMBLE, WASHINGTON & WOODFORD  
BOURBON (Southern two-thirds, including Townships of Austerlity,  
Centerville, Clintonville, Elizabeth, Hutchison, Littlerock,  
North Middletown & Paris);  
CARROLL (Western two-thirds, including Townships of Carrollton,  
Easterday, English, Locust, Louis, Prestonville & Worthville);  
CLARK (Western two-thirds, including Townships of Becknerville,  
Flanagan, Ford, Pine Grove, Winchester & Wyandotte);  
OWEN (Eastern eighth, including Townships of Glenmary, Gratz,  
Monterey, Perry Park & Tacketts Mill);  
SCOTT (Southern third, including Townships of Georgetown, Great  
Crossing, Newtown, Stampling Ground & Woodlake);

	Rates	Fringes
IRONWORKER.....	\$ 26.47	19.30

-----  
IRON0372-006 06/01/2013

BRACKEN, GALLATIN, GRANT, HARRISON and ROBERTSON  
BOURBON (Northern third, including Townships of Jackson,  
Millersburg, Ruddel Mills & Shawhan);  
CARROLL (Eastern third, including the Township of Ghent);  
FLEMING (Western part, Excluding Townships of Beechburg, Colfax,  
Elizaville, Flemingsburg, Flemingsburg Junction, Foxport,  
Grange City, Hillsboro, Hilltop, Mount Carmel, Muses Mills,  
Nepton, Pecksridge, Plummers Landing, Plummers Mill, Poplar  
Plains,  
Ringos Mills, Tilton & Wallingford);  
MASON (Western two-thirds, including Townships of Dover,  
Lewisburg, Mays Lick, Maysville, Minerva, Moranburg,  
Murphysville, Ripley, Sardis, Shannon, South Ripley &  
Washington);  
NICHOLAS (Townships of Barefoot, Barterville, Carlisle,  
Ellisville, Headquarters, Henryville, Morningglory, Myers &  
Oakland Mills);  
OWEN (Townships of Beechwood, Bromley, Fairbanks, Holbrook,  
Jonesville, Long Ridge, Lusby's Mill, New, New Columbus, New  
Liberty, Owenton, Poplar Grove, Rockdale, Sanders, Teresita &  
Wheatley);  
SCOTT (Northern two-thirds, including Townships of Biddle,  
Davis, Delaplain, Elmville, Longlick, Muddy Ford, Oxford, Rogers  
Gap, Sadieville, Skinnersburg & Stonewall) COUNTIES

	Rates	Fringes
--	-------	---------

IRONWORKER, REINFORCING.....\$ 26.47 19.30

-----  
IRON0769-007 12/01/2012

BATH, BOYD, CARTER, ELLIOTT, GREENUP, LEWIS, MONTGOMERY & ROWAN  
CLARK (Eastern third, including townships of Bloomingdale,  
Hunt, Indian Fields, Kiddville, Loglick, Rightangele & Thomson);  
FLEMING (Townships of Beechburg, Colfax, Elizaville,  
Flemingsburg, Flemingsburg Junction, Foxport, Grange City,  
Hillsboro, Hilltop, Mount Carmel, Muses Mills, Nepton,  
Pecksridge, Plummers Landing, Plummers Mill, Poplar Plains,  
Ringos Mills, Tilton & Wallingford);  
MASON (Eastern third, including Townships of Helena, Marshall,  
Orangeburg, Plumville & Springdale);  
NICHOLAS (Eastern eighth, including the Township of Moorefield  
Sprout)

Rates Fringes

IRONWORKER.....\$ 32.54 20.18

-----  
LABO0189-003 07/01/2013

BATH, BOURBON, BOYD, BOYLE, BRACKEN, CARTER, CLARK, ELLIOTT,  
FAYETTE, FLEMING, FRANKLIN, GALLATIN, GRANT, GREENUP, HARRISON,  
JESSAMINE, LEWIS, MADISON, MASON, MERCER, MONTGOMERY, NICHOLAS,  
OWEN, ROBERTSON, ROWAN, SCOTT, & WOOLFORD COUNTIES

Rates Fringes

Laborers:

GROUP 1.....	\$ 21.35	11.61
GROUP 2.....	\$ 21.60	11.61
GROUP 3.....	\$ 21.65	11.61
GROUP 4.....	\$ 22.25	11.61

LABORERS CLASSIFICATIONS

GROUP 1 - Aging & Curing of Concrete; Asbestos Abatement  
Worker; Asphalt Plant; Asphalt; Batch Truck Dump; Carpenter  
Tender; Cement Mason Tender; Cleaning of Machines;  
Concrete; Demolition; Dredging; Environmental - Nuclear,  
Radiation, Toxic & Hazardous Waste - Level D; Flagperson;  
Grade Checker; Hand Digging & Hand Back Filling; Highway  
Marker Placer; Landscaping, Mesh Handler & Placer; Puddler;  
Railroad; Rip-rap & Grouter; Right-of-Way; Sign, Guard Rail  
& Fence Installer; Signal Person; Sound Barrier Installer;  
Storm & Sanitary Sewer; Swamper; Truck Spotter & Dumper;  
Wrecking of Concrete Forms; General Cleanup

GROUP 2 - Batter Board Man (Sanitary & Storm Sewer);  
Brickmason Tender; Mortar Mixer Operator; Scaffold Builder;  
Burner & Welder; Bushhammer; Chain Saw Operator; Concrete  
Saw Operator; Deckhand Scow Man; Dry Cement Handler;  
Environmental - Nuclear, Radiation, Toxic & Hazardous Waste  
- Level C; Forklift Operator for Masonary; Form Setter;  
Green Concrete Cutting; Hand Operated Grouter & Grinder  
Machine Operator; Jackhammer; Pavement Breaker; Paving



Joint Machine; Pipelayer; Plastic Pipe Fusion; Power Driven Georgia Buggy & Wheel Barrow; Power Post Hole Digger; Precast Manhole Setter; Walk-Behind Tamper; Walk-Behind Trencher; Sand Blaster; Concrete Chipper; Surface Grinder; Vibrator Operator; Wagon Driller

GROUP 3 - Asphalt Luteman & Raker; Gunnite Nozzleman; Gunnite Operator & Mixer; Grout Pump Operator; Side Rail Setter; Rail Paved Ditches; Screw Operator; Tunnel (Free Air); Water Blaster

GROUP 4 - Caisson Worker (Free Air); Cement Finisher; Environmental - Nuclear, Radiation, Toxic & Hazardous Waste - Levels A & B; Miner & Driller (Free Air); Tunnel Blaster; & Tunnel Mucker (Free Air); Directional & Horizontal Boring; Air Track Drillers (All Types); Powdermen & Blasters; Troxler & Concrete Tester if Laborer is Utilized

-----  
LABO0189-008 07/01/2013

ANDERSON, BULLITT, CARROLL, HARDIN, HENRY, JEFFERSON, LARUE, MARION, MEADE, NELSON, OLDHAM, SHELBY, SPENCER, TRIMBLE & WASHINGTON COUNTIES

	Rates	Fringes
Laborers:		
GROUP 1.....	\$ 22.01	10.95
GROUP 2.....	\$ 22.26	10.95
GROUP 3.....	\$ 22.31	10.95
GROUP 4.....	\$ 22.91	10.95

#### LABORERS CLASSIFICATIONS

GROUP 1 - Aging & Curing of Concrete; Asbestos Abatement Worker; Asphalt Plant; Asphalt; Batch Truck Dump; Carpenter Tender; Cement Mason Tender; Cleaning of Machines; Concrete; Demolition; Dredging; Environmental - Nuclear, Radiation, Toxic & Hazardous Waste - Level D; Flaggperson; Grade Checker; Hand Digging & Hand Back Filling; Highway Marker Placer; Landscaping, Mesh Handler & Placer; Puddler; Railroad; Rip-rap & Grouter; Right-of-Way; Sign, Guard Rail & Fence Installer; Signal Person; Sound Barrier Installer; Storm & Sanitary Sewer; Swamper; Truck Spotter & Dumper; Wrecking of Concrete Forms; General Cleanup

GROUP 2 - Batter Board Man (Sanitary & Storm Sewer); Brickmason Tender; Mortar Mixer Operator; Scaffold Builder; Burner & Welder; Bushhammer; Chain Saw Operator; Concrete Saw Operator; Deckhand Scow Man; Dry Cement Handler; Environmental - Nuclear, Radiation, Toxic & Hazardous Waste - Level C; Forklift Operator for Masonary; Form Setter; Green Concrete Cutting; Hand Operated Grouter & Grinder Machine Operator; Jackhammer; Pavement Breaker; Paving Joint Machine; Pipelayer; Plastic Pipe Fusion; Power Driven Georgia Buggy & Wheel Barrow; Power Post Hole Digger; Precast Manhole Setter; Walk-Behind Tamper; Walk-Behind Trencher; Sand Blaster; Concrete Chipper; Surface Grinder;

Vibrator Operator; Wagon Driller

GROUP 3 - Asphalt Luteman & Raker; Gunnite Nozzleman;  
Gunnite Operator & Mixer; Grout Pump Operator; Side Rail  
Setter; Rail Paved Ditches; Screw Operator; Tunnel (Free  
Air); Water Blaster

GROUP 4 - Caisson Worker (Free Air); Cement Finisher;  
Environmental - Nuclear, Radiation, Toxic & Hazardous Waste  
- Levels A & B; Miner & Driller (Free Air); Tunnel Blaster;  
& Tunnel Mucker (Free Air); Directional & Horizontal  
Boring; Air Track Drillers (All Types); Powdermen &  
Blasters; Troxler & Concrete Tester if Laborer is Utilized

-----  
LABO0189-009 07/01/2013

BRECKINRIDGE & GRAYSON COUNTIES

	Rates	Fringes
Laborers:		
GROUP 1.....	\$ 21.96	11.00
GROUP 2.....	\$ 22.21	11.00
GROUP 3.....	\$ 22.26	11.00
GROUP 4.....	\$ 22.86	11.00

LABORERS CLASSIFICATIONS

GROUP 1 - Aging & Curing of Concrete; Asbestos Abatement  
Worker; Asphalt Plant; Asphalt; Batch Truck Dump; Carpenter  
Tender; Cement Mason Tender; Cleaning of Machines;  
Concrete; Demolition; Dredging; Environmental - Nuclear,  
Radiation, Toxic & Hazardous Waste - Level D; Flagperson;  
Grade Checker; Hand Digging & Hand Back Filling; Highway  
Marker Placer; Landscaping, Mesh Handler & Placer; Puddler;  
Railroad; Rip-rap & Grouter; Right-of-Way; Sign, Guard Rail  
& Fence Installer; Signal Person; Sound Barrier Installer;  
Storm & Sanitary Sewer; Swamper; Truck Spotter & Dumper;  
Wrecking of Concrete Forms; General Cleanup

GROUP 2 - Batter Board Man (Sanitary & Storm Sewer);  
Brickmason Tender; Mortar Mixer Operator; Scaffold Builder;  
Burner & Welder; Bushhammer; Chain Saw Operator; Concrete  
Saw Operator; Deckhand Scow Man; Dry Cement Handler;  
Environmental - Nuclear, Radiation, Toxic & Hazardous Waste  
- Level C; Forklift Operator for Masonary; Form Setter;  
Green Concrete Cutting; Hand Operated Grouter & Grinder  
Machine Operator; Jackhammer; Pavement Breaker; Paving  
Joint Machine; Pipelayer; Plastic Pipe Fusion; Power Driven  
Georgia Buggy & Wheel Barrow; Power Post Hole Digger;  
Precast Manhole Setter; Walk-Behind Tamper; Walk-Behind  
Trencher; Sand Blaster; Concrete Chipper; Surface Grinder;  
Vibrator Operator; Wagon Driller

GROUP 3 - Asphalt Luteman & Raker; Gunnite Nozzleman;  
Gunnite Operator & Mixer; Grout Pump Operator; Side Rail  
Setter; Rail Paved Ditches; Screw Operator; Tunnel (Free  
Air); Water Blaster

GROUP 4 - Caisson Worker (Free Air); Cement Finisher;  
 Environmental - Nuclear, Radiation, Toxic & Hazardous Waste  
 - Levels A & B; Miner & Driller (Free Air); Tunnel Blaster;  
 & Tunnel Mucker (Free Air); Directional & Horizontal  
 Boring; Air Track Drillers (All Types); Powdermen &  
 Blasters; Troxler & Concrete Tester if Laborer is Utilized

-----  
 PAIN0012-005 06/11/2005

BATH, BOURBON, BOYLE, CLARK, FAYETTE, FLEMING, FRANKLIN,  
 HARRISON, JESSAMINE, MADISON, MERCER, MONTGOMERY, NICHOLAS,  
 ROBERTSON, SCOTT & WOODFORD COUNTIES:

	Rates	Fringes
PAINTER		
Bridge/Equipment Tender and/or Containment Builder..	\$ 18.90	5.90
Brush & Roller.....	\$ 21.30	5.90
Elevated Tanks; Steeplejack Work; Bridge & Lead Abatement.....	\$ 22.30	5.90
Sandblasting & Waterblasting.....	\$ 22.05	5.90
Spray.....	\$ 21.80	5.90

-----  
 PAIN0012-017 05/01/2013

BRACKEN, GALLATIN, GRANT, MASON & OWEN COUNTIES:

	Rates	Fringes
PAINTER (Heavy & Highway Bridges - Guardrails - Lightpoles - Striping)		
Bridge Equipment Tender and Containment Builder.....	\$ 20.73	8.36
Brush & Roller.....	\$ 23.39	8.36
Elevated Tanks; Steeplejack Work; Bridge & Lead Abatement.....	\$ 24.39	8.36
Sandblasting & Water Blasting.....	\$ 24.14	8.36
Spray.....	\$ 23.89	8.36

-----  
 PAIN0118-004 05/01/2010

ANDERSON, BRECKINRIDGE, BULLITT, CARROLL, GRAYSON, HARDIN,  
 HENRY, JEFFERSON, LARUE, MARION, MEADE, NELSON, OLDHAM, SHELBY,  
 SPENCER, TRIMBLE & WASHINGTON COUNTIES:

	Rates	Fringes
PAINTER		
Brush & Roller.....	\$ 18.50	10.30
Spray, Sandblast, Power Tools, Waterblast & Steam		

Cleaning.....	\$ 19.50	10.30
---------------	----------	-------

-----  
PAIN1072-003 12/01/2012

BOYD, CARTER, ELLIOTT, GREENUP, LEWIS and ROWAN COUNTIES

	Rates	Fringes
--	-------	---------

Painters:

Bridges; Locks; Dams; Tension Towers & Energized Substations.....	\$ 30.18	14.65
Power Generating Facilities..	\$ 26.94	14.65

-----  
PLUM0248-003 06/01/2013

BOYD, CARTER, ELLIOTT, GREENUP, LEWIS & ROWAN COUNTIES:

	Rates	Fringes
--	-------	---------

Plumber and Steamfitter.....	\$ 33.00	17.93
------------------------------	----------	-------

-----  
PLUM0392-007 06/01/2013

BRACKEN, CARROLL (Eastern Half), GALLATIN, GRANT, MASON, OWEN &  
ROBERTSON COUNTIES:

	Rates	Fringes
--	-------	---------

Plumbers and Pipefitters.....	\$ 29.60	17.09
-------------------------------	----------	-------

-----  
PLUM0502-003 08/01/2013

BRECKINRIDGE, BULLITT, CARROLL (Western Half), FRANKLIN  
(Western three-fourths), GRAYSON, HARDIN, HENRY, JEFFERSON,  
LARUE, MARION, MEADE, NELSON, OLDHAM, SHELBY, SPENCER, TRIMBLE &  
WASHINGTON COUNTIES

	Rates	Fringes
--	-------	---------

PLUMBER.....	\$ 32.00	17.17
--------------	----------	-------

-----  
SUKY2010-160 10/08/2001

	Rates	Fringes
--	-------	---------

Truck drivers:

GROUP 1.....	\$ 16.57	7.34
GROUP 2.....	\$ 16.68	7.34
GROUP 3.....	\$ 16.86	7.34
GROUP 4.....	\$ 16.96	7.34

TRUCK DRIVER CLASSIFICATIONS

GROUP 1 - Mobile Batch Truck Tender

GROUP 2 - Greaser; Tire Changer; & Mechanic Tender

GROUP 3 - Single Axle Dump; Flatbed; Semi-trailer or Pole Trailer when used to pull building materials and equipment; Tandem Axle Dump; Distributor; Mixer; & Truck Mechanic

GROUP 4 - Euclid & Other Heavy Earthmoving Equipment & Lowboy; Articulator Cat; 5-Axle Vehicle; Winch & A-Frame when used in transporting materials; Ross Carrier; Forklift when used to transport building materials; & Pavement Breaker

-----

WELDERS - Receive rate prescribed for craft performing operation to which welding is incidental.

=====

Unlisted classifications needed for work not included within the scope of the classifications listed may be added after award only as provided in the labor standards contract clauses (29CFR 5.5 (a) (1) (ii)).

-----

The body of each wage determination lists the classification and wage rates that have been found to be prevailing for the cited type(s) of construction in the area covered by the wage determination. The classifications are listed in alphabetical order of "identifiers" that indicate whether the particular rate is union or non-union.

Union Identifiers

An identifier enclosed in dotted lines beginning with characters other than "SU" denotes that the union classification and rate have found to be prevailing for that classification. Example: PLUM0198-005 07/01/2011. The first four letters , PLUM, indicate the international union and the four-digit number, 0198, that follows indicates the local union number or district council number where applicable , i.e., Plumbers Local 0198. The next number, 005 in the example, is an internal number used in processing the wage determination. The date, 07/01/2011, following these characters is the effective date of the most current negotiated rate/collective bargaining agreement which would be July 1, 2011 in the above example.

Union prevailing wage rates will be updated to reflect any changes in the collective bargaining agreements governing the rates.

0000/9999: weighted union wage rates will be published annually each January.

## Non-Union Identifiers

Classifications listed under an "SU" identifier were derived from survey data by computing average rates and are not union rates; however, the data used in computing these rates may include both union and non-union data. Example: SULA2004-007 5/13/2010. SU indicates the rates are not union majority rates, LA indicates the State of Louisiana; 2004 is the year of the survey; and 007 is an internal number used in producing the wage determination. A 1993 or later date, 5/13/2010, indicates the classifications and rates under that identifier were issued as a General Wage Determination on that date.

Survey wage rates will remain in effect and will not change until a new survey is conducted.

-----

WAGE DETERMINATION APPEALS PROCESS

1.) Has there been an initial decision in the matter? This can be:

- \* an existing published wage determination
- \* a survey underlying a wage determination
- \* a Wage and Hour Division letter setting forth a position on a wage determination matter
- \* a conformance (additional classification and rate) ruling

On survey related matters, initial contact, including requests for summaries of surveys, should be with the Wage and Hour Regional Office for the area in which the survey was conducted because those Regional Offices have responsibility for the Davis-Bacon survey program. If the response from this initial contact is not satisfactory, then the process described in 2.) and 3.) should be followed.

With regard to any other matter not yet ripe for the formal process described here, initial contact should be with the Branch of Construction Wage Determinations. Write to:

Branch of Construction Wage Determinations  
Wage and Hour Division  
U.S. Department of Labor  
200 Constitution Avenue, N.W.  
Washington, DC 20210

2.) If the answer to the question in 1.) is yes, then an interested party (those affected by the action) can request review and reconsideration from the Wage and Hour Administrator (See 29 CFR Part 1.8 and 29 CFR Part 7). Write to:

Wage and Hour Administrator  
U.S. Department of Labor  
200 Constitution Avenue, N.W.  
Washington, DC 20210

The request should be accompanied by a full statement of the interested party's position and by any information (wage

payment data, project description, area practice material, etc.) that the requestor considers relevant to the issue.

3.) If the decision of the Administrator is not favorable, an interested party may appeal directly to the Administrative Review Board (formerly the Wage Appeals Board). Write to:

Administrative Review Board  
U.S. Department of Labor  
200 Constitution Avenue, N.W.  
Washington, DC 20210

4.) All decisions by the Administrative Review Board are final.

=====

END OF GENERAL DECISION

Fringe benefit amounts are applicable for all hours worked except when otherwise noted.

These rates are listed pursuant to the Kentucky Determination No. CR-13-III- HWY dated April 15, 2013.

No laborer, workman or mechanic shall be paid at a rate less than that of a Journeyman except those classified as bona fide apprentices.

Apprentices or trainees shall be permitted to work as such subject to Administrative Regulations adopted by the Commissioner of Workplace Standards. Copies of these regulations will be furnished upon request from any interested person.

Before using apprentices on the job the contractor shall present to the Contracting Officer written evidence of registration of such employees in a program of a State apprenticeship and training agency approved and recognized by the U. S. Bureau of Apprenticeship and Training. In the absence of such a State agency, the contractor shall submit evidence of approval and registration by the U. S. Bureau of Apprenticeship and Training.

The contractor shall submit to the Contracting Officer, written evidence of the established apprenticeship-journeyman ratios and wage rates in the project area, which will be the basis for establishing such ratios and rates for the project under the applicable contract provisions.

**TO: EMPLOYERS/EMPLOYEES**

**PREVAILING WAGE SCHEDULE:**

**The wages indicated on this wage schedule are the least permitted to be paid for the occupations indicated. When an employee works in more than one classification, the employer must record the number of hours worked in each classification at the prescribed hourly base rate.**

**OVERTIME:**

**Overtime is to be paid after an employee works eight (8) hours a day or forty (40) hours a week, whichever gives the employee the greater wages. At least time and one-half the base rate is required for all overtime. A laborer, workman or mechanic and an employer may enter into a written agreement or a collective bargaining agreement to work more than eight (8) hours a calendar day but not more than ten (10) hours a calendar day for the straight time hourly rate. Wage violations or questions should be directed to the designated Engineer or the undersigned.**

Ryan Griffith, Acting Director  
Division of Construction Procurement  
Frankfort, Kentucky 40622



## APPENDIX G

### Supplemental Specifications

**Supplemental Specifications to the  
Standard Specifications for Road and Bridge Construction, 2012 Edition  
Effective with the September 27, 2013 Letting**

<b>Subsection:</b>	108.03 Preconstruction Conference.
<b>Revision:</b>	Replace 8) Staking with the following: 8) Staking (designated by a Professional Engineer or Land Surveyor licensed in the Commonwealth of Kentucky.
<b>Subsection:</b>	109.07.02 Fuel.
<b>Revision:</b>	Revise item Crushed Aggregate Used for Embankment Stabilization to the following: Crushed Aggregate Used for Stabilization of Unsuitable Materials Used for Embankment Stabilization
<b>Subsection:</b>	110.02 Demobilization.
<b>Revision:</b>	Replace the first part of the first sentence of the second paragraph with the following: Perform all work and operations necessary to accomplish final clean-up as specified in the first paragraph of Subsection 105.12;
<b>Subsection:</b>	112.03.12 Project Traffic Coordinator (PTC).
<b>Revision:</b>	Replace the last paragraph of this subsection with the following: Ensure the designated PTC has sufficient skill and experience to properly perform the task assigned and has successfully completed the qualification courses.
<b>Subsection:</b>	112.04.18 Diversions (By-Pass Detours).
<b>Revision:</b>	Insert the following sentence after the 2nd sentence of this subsection. The Department will not measure temporary drainage structures for payment when the contract documents provide the required drainage opening that must be maintained with the diversion. The temporary drainage structures shall be incidental to the construction of the diversion. If the contract documents fail to provide the required drainage opening needed for the diversion, the cost of the temporary drainage structure will be handled as extra work in accordance with section 109.04.
<b>Subsection:</b>	201.03.01 Contractor Staking.
<b>Revision:</b>	Replace the first paragraph with the following: Perform all necessary surveying under the general supervision of a Professional Engineer or Land Surveyor licensed in the Commonwealth of Kentucky.
<b>Subsection:</b>	201.04.01 Contractor Staking.
<b>Revision:</b>	Replace the last sentence of the paragraph with the following: Complete the general layout of the project under the supervision of a Professional Engineer or Land Surveyor licensed in the Commonwealth of Kentucky.
<b>Subsection:</b>	206.04.01 Embankment-in-Place.
<b>Revision:</b>	Replace the fourth paragraph with the following: The Department will not measure <b>suitable</b> excavation included in the original plans that is disposed of for payment and will consider it incidental to Embankment-in-Place.
<b>Subsection:</b>	208.02.01 Cement.
<b>Revision:</b>	Replace paragraph with the following: Select Type I or Type II cement conforming to Section 801. Use the same type cement throughout the work.

**Supplemental Specifications to the  
Standard Specifications for Road and Bridge Construction, 2012 Edition  
Effective with the September 27, 2013 Letting**

<b>Subsection:</b>	208.03.06 Curing and Protection.
<b>Revision:</b>	Replace the fourth paragraph with the following: Do not allow traffic or equipment on the finished surface until the stabilized subgrade has cured for a total of 7-days with an ambient air temperature above 40 degrees Fahrenheit. A curing day consists of a continuous 24-hour period in which the ambient air temperature does not fall below 40 degrees Fahrenheit. Curing days will not be calculated consecutively, but must total seven (7) , 24-hour days with the ambient air temperature remaining at or above 40 degrees Fahrenheit before traffic or equipment will be allowed to traverse the stabilized subgrade. The Department may allow a shortened curing period when the Contractor requests. The Contractor shall give the Department at least 3 day notice of the request for a shortened curing period. The Department will require a minimum of 3 curing days after final compaction. The Contractor shall furnish cores to the treated depth of the roadbed at 500 feet intervals for each lane when a shortened curing time is requested. The Department will test cores using an unconfined compression test. Roadbed cores must achieve a minimum strength requirement of 80 psi.
<b>Subsection:</b>	208.03.06 Curing and Protection.
<b>Revision:</b>	Replace paragraph nine with the following: At no expense to the Department, repair any damage to the subgrade caused by freezing.
<b>Subsection:</b>	212.03.03 Permanent Seeding and Protection.
<b>Part:</b>	A) Seed Mixtures for Permanent Seeding.
<b>Number:</b>	2)
<b>Revision:</b>	Replace the paragraph with the following: Permanent Seeding on Slopes Greater than 3:1 in Highway Districts 4, 5, 6, and 7. Apply seed mix Type II at a minimum application rate of 100 pounds per acre. If adjacent to a golf course replace the crown vetch with Kentucky 31 Tall Fescue.
<b>Subsection:</b>	212.03.03 Permanent Seeding and Protection.
<b>Part:</b>	A) Seed Mixtures for Permanent Seeding.
<b>Number:</b>	3)
<b>Revision:</b>	Replace the paragraph with the following: Permanent Seeding on Slopes Greater than 3:1 in Highway Districts 1, 2, 3, 8, 9, 10, 11, and 12. Apply seed mix Type III at a minimum application rate of 100 pounds per acre. If adjacent to crop land or golf course, replace the Sericea Lespedeza with Kentucky 31 Fescue.
<b>Subsection:</b>	213.03.02 Progress Requirements.
<b>Revision:</b>	Replace the last sentence of the third paragraph with the following: Additionally, the Department will apply a penalty equal to the liquidated damages when all aspects of the work are not coordinated in an acceptable manner within 7 calendar days after written notification.
<b>Subsection:</b>	213.03.05 Temporary Control Measures.
<b>Part:</b>	E) Temporary Seeding and Protection.
<b>Revision:</b>	Delete the second sentence of the first paragraph.
<b>Subsection:</b>	304.02.01 Physical Properties.
<b>Table:</b>	Required Geogrid Properties
<b>Revision:</b>	Replace all references to Test Method "GRI-GG2-87" with ASTM D 7737.

**Supplemental Specifications to the  
Standard Specifications for Road and Bridge Construction, 2012 Edition  
Effective with the September 27, 2013 Letting**

<b>Subsection:</b> <b>Part:</b> <b>Revision:</b>	402.03.02 Contractor Quality Control and Department Acceptance. B) Sampling. Replace the second sentence with the following: The Department will determine when to obtain the quality control samples using the random-number feature of the mix design submittal and approval spreadsheet. The Department will randomly determine when to obtain the verification samples required in Subsections 402.03.03 and 402.03.04 using the Asphalt Mixture Sample Random Tonnage Generator.
<b>Subsection:</b> <b>Part:</b> <b>Number:</b> <b>Revision:</b>	402.03.02 Contractor Quality Control and Department Acceptance. D) Testing Responsibilities. 3) VMA. Add the following paragraph below Number 3) VMA: Retain the AV/VMA specimens and one additional corresponding $G_{mm}$ sample for 5 working days for mixture verification testing by the Department. For Specialty Mixtures, retain a mixture sample for 5 working days for mixture verification testing by the Department. When the Department's test results do not verify that the Contractor's quality control test results are within the acceptable tolerances according to Subsection 402.03.03, retain the samples and specimens from the affected subplot(s) for the duration of the project.
<b>Subsection:</b> <b>Part:</b> <b>Number:</b> <b>Revision:</b>	402.03.02 Contractor Quality Control and Department Acceptance. D) Testing Responsibilities. 4) Density. Replace the second sentence of the Option A paragraph with the following: Perform coring by the end of the following work day.
<b>Subsection:</b> <b>Part:</b> <b>Number:</b> <b>Revision:</b>	402.03.02 Contractor Quality Control and Department Acceptance. D) Testing Responsibilities. 5) Gradation. Delete the second paragraph.
<b>Subsection:</b> <b>Part:</b> <b>Number:</b> <b>Revision:</b>	402.03.02 Contractor Quality Control and Department Acceptance. H) Unsatisfactory Work. 1) Based on Lab Data. Replace the second paragraph with the following: When the Engineer determines that safety concerns or other considerations prohibit an immediate shutdown, continue work and the Department will make an evaluation of acceptability according to Subsection 402.03.05.

**Supplemental Specifications to the  
Standard Specifications for Road and Bridge Construction, 2012 Edition  
Effective with the September 27, 2013 Letting**

<b>Subsection:</b> <b>Revision:</b>	402.03.03 Verification. Replace the first paragraph with the following: <b>402.03.03 Mixture Verification.</b> For volumetric properties, the Department will perform a minimum of one verification test for AC, AV, and VMA according to the corresponding procedures as given in Subsection 402.03.02. The Department will randomly determine when to obtain the verification sample using the Asphalt Mixture Sample Random Tonnage Generator. For specialty mixtures, the Department will perform one AC and one gradation determination per lot according to the corresponding procedures as given in Subsection 402.03.02. However, Department personnel will not perform AC determinations according to KM 64-405. The Contractor will obtain a quality control sample at the same time the Department obtains the mixture verification sample and perform testing according to the procedures given in Subsection 402.03.02. If the Contractor's quality control sample is verified by the Department's test results within the tolerances provided below, the Contractor's sample will serve as the quality control sample for the affected subplot. The Department may perform the mixture verification test on the Contractor's equipment or on the Department's equipment.
<b>Subsection:</b> <b>Part:</b> <b>Revision:</b>	402.03.03 Verification. A) Evaluation of Sublot(s) Verified by Department. Replace the third sentence of the second paragraph with the following: When the paired <i>t</i> -test indicates that the Contractor's data and Department's data are possibly not from the same population, the Department will investigate the cause for the difference according to Subsection 402.03.05 and implement corrective measures as the Engineer deems appropriate.
<b>Subsection:</b> <b>Part:</b> <b>Revision:</b>	402.03.03 Verification. B) Evaluation of Sublots Not Verified by Department. Replace the third sentence of the first paragraph with the following: When differences between test results are not within the tolerances listed below, the Department will resolve the discrepancy according to Subsection 402.03.05.
<b>Subsection:</b> <b>Part:</b> <b>Revision:</b>	402.03.03 Verification. B) Evaluation of Sublots Not Verified by Department. Replace the third sentence of the second paragraph with the following: When the <i>F</i> -test or <i>t</i> -test indicates that the Contractor's data and Department's data are possibly not from the same population, the Department will investigate the cause for the difference according to Subsection 402.03.05 and implement corrective measures as the Engineer deems appropriate.
<b>Subsection:</b> <b>Part:</b> <b>Revision:</b>	402.03.03 Verification. C) Test Data Patterns. Replace the second sentence with the following: When patterns indicate substantial differences between the verified and non-verified sublots, the Department will perform further comparative testing according to subsection 402.03.05.

**Supplemental Specifications to the  
Standard Specifications for Road and Bridge Construction, 2012 Edition  
Effective with the September 27, 2013 Letting**

<b>Subsection:</b>	402.03 CONSTRUCTION.
<b>Revision:</b>	Add the following subsection: <b>402.03.04 Testing Equipment and Technician Verification.</b> For mixtures with a minimum quantity of 20,000 tons and for every 20,000 tons thereafter, the Department will obtain an additional verification sample at random using the Asphalt Mixture Sample Random Tonnage Generator in order to verify the integrity of the Contractor's and Department's laboratory testing equipment and technicians. The Department will obtain a mixture sample of at least 150 lb at the asphalt mixing plant according to KM 64-425 and split it according to AASHTO R 47. The Department will retain one split portion of the sample and provide the other portion to the Contractor. At a later time convenient to both parties, the Department and Contractor will simultaneously reheat the sample to the specified compaction temperature and test the mixture for AV and VMA using separate laboratory equipment according to the corresponding procedures given in Subsection 402.03.02. The Department will evaluate the differences in test results between the two laboratories. When the difference between the results for AV or VMA is not within $\pm 2.0$ percent, the Department will investigate and resolve the discrepancy according to Subsection 402.03.05.
<b>Subsection:</b>	402.03.04 Dispute Resolution.
<b>Revision:</b>	Change the subsection number to 402.03.05.
<b>Subsection:</b>	402.05 PAYMENT.
<b>Part:</b>	Lot Pay Adjustment Schedule Compaction Option A Base and Binder Mixtures
<b>Table:</b>	AC
<b>Revision:</b>	Replace the Deviation from JMF(%) that corresponds to a Pay Value of 0.95 to $\pm 0.6$ .
<b>Subsection:</b>	403.02.10 Material Transfer Vehicle (MTV).
<b>Revision:</b>	Replace the first sentence with the following: In addition to the equipment specified above, provide a MTV with the following minimum characteristics:
<b>Subsection:</b>	412.02.09 Material Transfer Vehicle (MTV).
<b>Revision:</b>	Replace the paragraph with the following: Provide and utilize a MTV with the minimum characteristics outlined in section 403.02.10.
<b>Subsection:</b>	412.03.07 Placement and Compaction.
<b>Revision:</b>	Replace the first paragraph with the following: Use a MTV when placing SMA mixture in the driving lanes. The MTV is not required on ramps and/or shoulders unless specified in the contract. When the Engineer determines the use of the MTV is not practical for a portion of the project, the Engineer may waive its requirement for that portion of pavement by a letter documenting the waiver.
<b>Subsection:</b>	412.04 MEASUREMENT.
<b>Revision:</b>	Add the following subsection: 412.04.03. Material Transfer Vehicle (MTV). The Department will not measure the MTV for payment and will consider its use incidental to the asphalt mixture.

**Supplemental Specifications to the  
Standard Specifications for Road and Bridge Construction, 2012 Edition  
Effective with the September 27, 2013 Letting**

<b>Subsection:</b>	501.03.19 Surface Tolerances and Testing Surface.
<b>Part:</b>	B) Ride Quality.
<b>Revision:</b>	Add the following to the end of the first paragraph: The Department will specify if the ride quality requirements are Category A or Category B when ride quality is specified in the Contract. Category B ride quality requirements shall apply when the Department fails to classify which ride quality requirement will apply to the Contract.
<b>Subsection:</b>	603.03.06 Cofferdams.
<b>Revision:</b>	Replace the seventh sentence of paragraph one with the following: Submit drawings that are stamped by a Professional Engineer licensed in the Commonwealth of Kentucky.
<b>Subsection:</b>	605.03.04 Tack Welding.
<b>Revision:</b>	Insert the subsection and the following: 605.03.04 Tack Welding. The Department does not allow tack welding.
<b>Subsection:</b>	606.03.17 Special Requirements for Latex Concrete Overlays.
<b>Part:</b>	A) Existing Bridges and New Structures.
<b>Number:</b>	1) Prewetting and Grout-Bond Coat.
<b>Revision:</b>	Add the following sentence to the last paragraph: Do not apply a grout-bond coat on bridge decks prepared by hydrodemolition.
<b>Subsection:</b>	609.03 Construction.
<b>Revision:</b>	Replace Subsection 609.03.01 with the following: 609.03.01 A) Swinging the Spans. Before placing concrete slabs on steel spans or precast concrete release the temporary erection supports under the bridge and swing the span free on its supports. 609.03.01 B) Lift Loops. Cut all lift loops flush with the top of the precast beam once the beam is placed in the final location and prior to placing steel reinforcement. At locations where lift loops are cut, paint the top of the beam with galvanized or epoxy paint.
<b>Subsection:</b>	611.03.02 Precast Unit Construction.
<b>Revision:</b>	Replace the first sentence of the subsection with the following: Construct units according to ASTM C1577, <b>replacing Table 1 (Design Requirements for Precast Concrete Box Sections Under Earth, Dead and HL-93 Live Load Conditions) with KY Table 1 (Precast Culvert KYHL-93 Design Table)</b> , and Section 605 with the following exceptions and additions:
<b>Subsection:</b>	613.03.01 Design.
<b>Number:</b>	2)
<b>Revision:</b>	Replace "AASHTO Standard Specifications for Highway Bridges" with "AASHTO LRFD Bridge Design Specifications"
<b>Subsection:</b>	615.06.02
<b>Revision:</b>	Add the following sentence to the end of the subsection. The ends of units shall be normal to walls and centerline except exposed edges shall be beveled $\frac{3}{4}$ inch.
<b>Subsection:</b>	615.06.03 Placement of Reinforcement in Precast 3-Sided Units.
<b>Revision:</b>	Replace the reference of 6.6 in the section to 615.06.06.
<b>Subsection:</b>	615.06.04 Placement of Reinforcement for Precast Endwalls.
<b>Revision:</b>	Replace the reference of 6.7 in the section to 615.06.07.

**Supplemental Specifications to the  
Standard Specifications for Road and Bridge Construction, 2012 Edition  
Effective with the September 27, 2013 Letting**

<b>Subsection:</b>	615.06.06 Laps, Welds, and Spacing for Precast 3-Sided Units.
<b>Revision:</b>	Replace the subsection with the following: Tension splices in the circumferential reinforcement shall be made by lapping. Laps may not be tack welded together for assembly purposes. For smooth welded wire fabric, the overlap shall meet the requirements of AASHTO 2012 Bridge Design Guide Section 5.11.2.5.2 and AASHTO 2012 Bridge Design Guide Section 5.11.6.3. For deformed welded wire fabric, the overlap shall meet the requirements of AASHTO 2012 Bridge Design Guide Section 5.11.2.5.1 and AASHTO 2012 Bridge Design Guide Section 5.11.6.2. The overlap of welded wire fabric shall be measured between the outer most longitudinal wires of each fabric sheet. For deformed billet-steel bars, the overlap shall meet the requirements of AASHTO 2012 Bridge Design Guide Section 5.11.2.1. For splices other than tension splices, the overlap shall be a minimum of 12" for welded wire fabric or deformed billet-steel bars. The spacing center to center of the circumferential wires in a wire fabric sheet shall be no less than 2 inches and no more than 4 inches. The spacing center to center of the longitudinal wires shall not be more than 8 inches. The spacing center to center of the longitudinal distribution steel for either line of reinforcing in the top slab shall be not more than 16 inches.
<b>Subsection:</b>	615.06.07 Laps, Welds, and Spacing for Precast Endwalls.
<b>Revision:</b>	Replace the subsection with the following: Splices in the reinforcement shall be made by lapping. Laps may not be tack welded together for assembly purposes. For smooth welded wire fabric, the overlap shall meet the requirements of AASHTO 2012 Bridge Design Guide Section 5.11.2.5.2 and AASHTO 2012 Bridge Design Guide Section 5.11.6.3. For deformed welded wire fabric, the overlap shall meet the requirements of AASHTO 2012 Bridge Design Guide Section 5.11.2.5.1 and AASHTO 2012 Bridge Design Guide Section 5.11.6.2. For deformed billet-steel bars, the overlap shall meet the requirements of AASHTO 2012 Bridge Design Guide Section 5.11.2.1. The spacing center-to-center of the wire fabric sheet shall not be less than 2 inches or more than 8 inches.
<b>Subsection:</b>	615.08.01 Type of Test Specimen.
<b>Revision:</b>	Replace the subsection with the following: Start-up slump, air content, unit weight, and temperature tests will be performed each day on the first batch of concrete. Acceptable start-up results are required for production of the first unit. After the first unit has been established, random acceptance testing is performed daily for each 50 yd <sup>3</sup> (or fraction thereof). In addition to the slump, air content, unit weight, and temperature tests, a minimum of one set of cylinders shall be required each time plastic property testing is performed.
<b>Subsection:</b>	615.08.02 Compression Testing.
<b>Revision:</b>	Delete the second sentence.
<b>Subsection:</b>	615.08.04 Acceptability of Core Tests.
<b>Revision:</b>	Delete the entire subsection.
<b>Subsection:</b>	615.12 Inspection.
<b>Revision:</b>	Add the following sentences to the end of the subsection: Units will arrive at jobsite with the "Kentucky Oval" stamped on the unit which is an indication of acceptable inspection at the production facility. Units shall be inspected upon arrival for any evidence of damage resulting from transport to the jobsite.



**Supplemental Specifications to the  
Standard Specifications for Road and Bridge Construction, 2012 Edition  
Effective with the September 27, 2013 Letting**

<b>Subsection:</b>	716.02.02 Paint.
<b>Revision:</b>	Replace sentence with the following: Conform to Section 821.
<b>Subsection:</b>	716.03 CONSTRUCTION.
<b>Revision:</b>	Replace bullet 5) with the following: 5) AASHTO Standard Specifications for Structural Supports for Highway Signs, Luminaires, and Traffic Signals, 2013-6th Edition with current interims,
<b>Subsection:</b>	716.03.02 Lighting Standard Installation.
<b>Revision:</b>	Replace the second sentence with the following: Regardless of the station and offset noted, locate all poles/bases behind the guardrail a minimum of four feet from the front face of the guardrail to the front face of the pole base.
<b>Subsection:</b>	716.03.02 Lighting Standard Installation.
<b>Part:</b>	A) Conventional Installation.
<b>Revision:</b>	Replace the third sentence with the following: Orient the transformer base so the door is positioned on the side away from on-coming traffic.
<b>Subsection:</b>	716.03.02 Lighting Standard Installation.
<b>Part:</b>	A) Conventional Installation.
<b>Number:</b>	1) Breakaway Installation and Requirements.
<b>Revision:</b>	Replace the first sentence with the following: For breakaway supports, conform to Section 12 of the AASHTO Standard Specifications for Structural Supports for Highway Signs, Luminaires, and Traffic Signals, 2013-6th Edition with current interims.
<b>Subsection:</b>	716.03.02 Lighting Standard Installation.
<b>Part:</b>	B) High Mast Installation
<b>Revision:</b>	Replace the first sentence with the following: Install each high mast pole as noted on plans.
<b>Subsection:</b>	716.03.02 Lighting Standard Installation.
<b>Part:</b>	B) High Mast Installation
<b>Number:</b>	2) Concrete Base Installation
<b>Revision:</b>	Modification of Chart and succeeding paragraphs within this section:

Drilled Shaft Depth Data							
Level Ground		3:1 Ground Slope		2:1 Ground Slope		1.5:1 Ground Slope <sup>(2)</sup>	
Soil	Rock	Soil	Rock	Soil	Rock	Soil	Rock
17 ft	7 ft	19 ft	7 ft	20 ft	7 ft	<sup>(1)</sup>	7 ft
Steel Requirements							
Vertical Bars				Ties or Spiral			
Size	Total	Size	Spacing or Pitch				
#10	16	#4	12 inch				

**Supplemental Specifications to the  
Standard Specifications for Road and Bridge Construction, 2012 Edition  
Effective with the September 27, 2013 Letting**

	<p>(1): Shaft length is 22' for cohesive soil only. For cohesionless soil, contact geotechnical branch for design.</p> <p>(2): Do not construct high mast drilled shafts on ground slopes steeper than 1.5:1 without the approval of the Division of Traffic.</p> <p>If rock is encountered during drilling operations and confirmed by the engineer to be of sound quality, the shaft is only required to be further advanced into the rock by the length of rock socket shown in the table. The total length of the shaft need not be longer than that of soil alone. Both longitudinal rebar length and number of ties or spiral length shall be adjusted accordingly.</p> <p>If a shorter depth is desired for the drilled shaft, the contractor shall provide, for the state's review and approval, a detailed column design with individual site specific soil and rock analysis performed and approved by a Professional Engineer licensed in the Commonwealth of Kentucky.</p> <p>Spiral reinforcement may be substituted for ties. If spiral reinforcement is used, one and one-half closed coils shall be provided at the ends of each spiral unit. Subsurface conditions consisting of very soft clay or very loose saturated sand could result in soil parameters weaker than those assumed. Engineer shall consult with the geotechnical branch if such conditions are encountered.</p> <p>The bottom of the drilled hole shall be firm and thoroughly cleaned so no loose or compressible materials are present at the time of the concrete placement. If the drilled hole contains standing water, the concrete shall be placed using a tremie to displace water. Continuous concrete flow will be required to insure full displacement of any water.</p> <p>The reinforcement and anchor bolts shall be adequately supported in the proper positions so no movement occurs during concrete placement. Welding of anchor bolts to the reinforcing cage is unacceptable, templates shall be used.</p> <p>Exposed portions of the foundation shall be formed to create a smooth finished surface. All forming shall be removed upon completion of foundation construction.</p>
<p><b>Subsection:</b> <b>Part:</b> <b>Revision:</b></p>	<p>716.03.03 Trenching. A) Trenching of Conduit for Highmast Ducted Cables. Add the following after the first sentence: If depths greater than 24 inches are necessary, obtain the Engineer's approval and maintain the required conduit depths coming into the junction boxes. No payment for additional junction boxes for greater depths will be allowed.</p>
<p><b>Subsection:</b> <b>Part:</b> <b>Revision:</b></p>	<p>716.03.03 Trenching. B) Trenching of Conduit for Non-Highmast Cables. Add the following after the second sentence: If depths greater than 24 inches are necessary for either situation listed previously, obtain the Engineer's approval and maintain the required conduit depths coming into the junction boxes. No payment for additional junction boxes for greater depths will be allowed.</p>
<p><b>Subsection:</b> <b>Revision:</b></p>	<p>716.03.10 Junction Boxes. Replace subsection title with the following: Electrical Junction Box.</p>

**Supplemental Specifications to the  
Standard Specifications for Road and Bridge Construction, 2012 Edition  
Effective with the September 27, 2013 Letting**

<b>Subsection:</b>	716.04.07 Pole with Secondary Control Equipment.
<b>Revision:</b>	Replace the paragraph with the following: The Department will measure the quantity as each individual unit furnished and installed. The Department will not measure mounting the cabinet to the pole, backfilling, restoration, any necessary hardware to anchor pole, or electrical inspection fees, and will consider them incidental to this item of work. The Department will also not measure furnishing and installing electrical service conductors, specified conduits, meter base, transformer, service panel, fused cutout, fuses, lighting arrestors, photoelectrical control, circuit breaker, contactor, manual switch, ground rods, and ground wires and will consider them incidental to this item of work.
<b>Subsection:</b>	716.04.08 Lighting Control Equipment.
<b>Revision:</b>	Replace the paragraph with the following: The Department will measure the quantity as each individual unit furnished and installed. The Department will not measure constructing the concrete base, excavation, backfilling, restoration, any necessary anchors, or electrical inspection fees, and will consider them incidental to this item of work. The Department will also not measure furnishing and installing electrical service conductors, specified conduits, meter base, transformer, service panel, fused cutout, fuses, lighting arrestors, photoelectrical control, circuit breakers, contactor, manual switch, ground rods, and ground wires and will consider them incidental to this item of work.
<b>Subsection:</b>	716.04.09 Luminaire.
<b>Revision:</b>	Replace the first sentence with the following: The Department will measure the quantity as each individual unit furnished and installed.
<b>Subsection:</b>	716.04.10 Fused Connector Kits.
<b>Revision:</b>	Replace the first sentence with the following: The Department will measure the quantity as each individual unit furnished and installed.
<b>Subsection:</b>	716.04.13 Junction Box.
<b>Revision:</b>	Replace the subsection title with the following: Electrical Junction Box Type Various.
<b>Subsection:</b>	716.04.13 Junction Box.
<b>Part:</b>	A) Junction Electrical.
<b>Revision:</b>	Rename A) Junction Electrical to the following: A) Electrical Junction Box.
<b>Subsection:</b>	716.04.14 Trenching and Backfilling.
<b>Revision:</b>	Replace the second sentence with the following: The Department will not measure excavation, backfilling, underground utility warning tape (if required), the restoration of disturbed areas to original condition, and will consider them incidental to this item of work.
<b>Subsection:</b>	716.04.18 Remove Lighting.
<b>Revision:</b>	Replace the paragraph with the following: The Department will measure the quantity as a lump sum for the removal of lighting equipment. The Department will not measure the disposal of all equipment and materials off the project by the contractor. The Department also will not measure the transportation of the materials and will consider them incidental to this item of work.

**Supplemental Specifications to the  
Standard Specifications for Road and Bridge Construction, 2012 Edition  
Effective with the September 27, 2013 Letting**

<b>Subsection:</b>	716.04.20 Bore and Jack Conduit.															
<b>Revision:</b>	Replace the paragraph with the following: The Department will measure the quantity in linear feet. This item shall include all work necessary for boring and installing conduit under an existing roadway. Construction methods shall be in accordance with Sections 706.03.02, paragraphs 1, 2, and 4.															
<b>Subsection:</b>	716.05 PAYMENT.															
<b>Revision:</b>	Replace items 04810-04811, 20391NS835 and, 20392NS835 under <u>Code</u> , <u>Pay Item</u> , and <u>Pay Unit</u> with the following:															
	<table style="width: 100%; border-collapse: collapse;"> <thead> <tr> <th style="text-align: left;"><u>Code</u></th> <th style="text-align: left;"><u>Pay Item</u></th> <th style="text-align: left;"><u>Pay Unit</u></th> </tr> </thead> <tbody> <tr> <td>04810</td> <td>Electrical Junction Box</td> <td>Each</td> </tr> <tr> <td>04811</td> <td>Electrical Junction Box Type B</td> <td>Each</td> </tr> <tr> <td>20391NS835</td> <td>Electrical Junction Box Type A</td> <td>Each</td> </tr> <tr> <td>20391NS835</td> <td>Electrical Junction Box Type C</td> <td>Each</td> </tr> </tbody> </table>	<u>Code</u>	<u>Pay Item</u>	<u>Pay Unit</u>	04810	Electrical Junction Box	Each	04811	Electrical Junction Box Type B	Each	20391NS835	Electrical Junction Box Type A	Each	20391NS835	Electrical Junction Box Type C	Each
<u>Code</u>	<u>Pay Item</u>	<u>Pay Unit</u>														
04810	Electrical Junction Box	Each														
04811	Electrical Junction Box Type B	Each														
20391NS835	Electrical Junction Box Type A	Each														
20391NS835	Electrical Junction Box Type C	Each														
<b>Subsection:</b>	723.03 CONSTRUCTION.															
<b>Revision:</b>	Replace bullet 5) with the following: 5) AASHTO Standard Specifications for Structural Supports for Highway Signs, Luminaires, and Traffic Signals, 2013-6th Edition with current interims,															
<b>Subsection:</b>	723.02.02 Paint.															
<b>Revision:</b>	Replace sentence with the following: Conform to Section 821.															
<b>Subsection:</b>	723.03.02 Poles and Bases Installation.															
<b>Revision:</b>	Replace the first sentence with the following: Regardless of the station and offset noted, locate all poles/bases behind the guardrail a minimum of four feet from the front face of the guardrail to the front face of the pole base.															
<b>Subsection:</b>	723.03.02 Poles and Bases Installation.															
<b>Part:</b>	A) Steel Strain and Mastarm Poles Installation															
<b>Revision:</b>	Replace the second paragraph with the following: For concrete base installation, see Section 716.03.02, B), 2), Paragraphs 2-7. Drilled shaft depth shall be based on the soil conditions encountered during drilling and slope condition at the site. Refer to the design chart below:															
<b>Subsection:</b>	723.03.02 Poles and Bases Installation.															
<b>Part:</b>	B) Pedestal or Pedestal Post Installation.															
<b>Revision:</b>	Replace the fourth sentence of the paragraph with the following: For breakaway supports, conform to Section 12 of the AASHTO Standard Specifications for Structural Supports for Highway Signs, Luminaires, and Traffic Signals, 2013-6th Edition with current interims.															
<b>Subsection:</b>	723.03.03 Trenching.															
<b>Part:</b>	A) Under Roadway.															
<b>Revision:</b>	Add the following after the second sentence: If depths greater than 24 inches are necessary, obtain the Engineer's approval and maintain ether required conduit depths coming into the junction boxes. No payment for additional junction boxes for greater depths will be allowed.															

**Supplemental Specifications to the  
Standard Specifications for Road and Bridge Construction, 2012 Edition  
Effective with the September 27, 2013 Letting**

<b>Subsection:</b>	723.03.11 Wiring Installation.
<b>Revision:</b>	Add the following sentence between the fifth and sixth sentences: Provide an extra two feet of loop wire and lead-in past the installed conduit in poles, pedestals, and junction boxes.
<b>Subsection:</b>	723.03.12 Loop Installation.
<b>Revision:</b>	Replace the fifth sentence with the following: Provide an extra two feet of loop wire and lead-in past the installed conduit in poles, pedestals, and junction boxes.
<b>Subsection:</b>	723.04.02 Junction Box.
<b>Revision:</b>	Replace subsection title with the following: Electrical Junction Box Type.
<b>Subsection:</b>	723.04.03 Trenching and Backfilling.
<b>Revision:</b>	Replace the second sentence with the following: The Department will not measure excavation, backfilling, underground utility warning tape (if required), the restoration of disturbed areas to original condition, and will consider them incidental to this item of work.
<b>Subsection:</b>	723.04.10 Signal Pedestal.
<b>Revision:</b>	Replace the second sentence with the following: The Department will not measure excavation, concrete, reinforcing steel, specified conduits, fittings, ground rod, ground wire, backfilling, restoring disturbed areas, or other necessary hardware and will consider them incidental to this item of work.
<b>Subsection:</b>	723.04.15 Loop Saw Slot and Fill.
<b>Revision:</b>	Replace the second sentence with the following: The Department will not measure sawing, cleaning and filling induction loop saw slot, loop sealant, backer rod, and grout and will consider them incidental to this item of work.
<b>Subsection:</b>	723.04.16 Pedestrian Detector.
<b>Revision:</b>	Replace the paragraph with the following: The Department will measure the quantity as each individual unit furnished, installed and connected to pole/pedestal. The Department will not measure installing R10-3e (with arrow) sign, furnishing and installing mounting hardware for sign and will consider them incidental to this item of work.
<b>Subsection:</b>	723.04.18 Signal Controller- Type 170.
<b>Revision:</b>	Replace the second sentence with the following: The Department will not measure constructing the concrete base or mounting the cabinet to the pole, connecting the signal and detectors, excavation, backfilling, restoration, any necessary pole mounting hardware, electric service, or electrical inspection fees and will consider them incidental to this item of work. The Department will also not measure furnishing and connecting the induction of loop amplifiers, pedestrian isolators, load switches, model 400 modem card; furnishing and installing electrical service conductors, specified conduits, anchors, meter base, fused cutout, fuses, ground rods, ground wires and will consider them incidental to this item of work.

**Supplemental Specifications to the  
Standard Specifications for Road and Bridge Construction, 2012 Edition  
Effective with the September 27, 2013 Letting**

<b>Subsection:</b>	723.04.20 Install Signal Controller - Type 170.
<b>Revision:</b>	Replace the paragraph with the following: The Department will measure the quantity as each individual unit installed. The Department will not measure constructing the concrete base or mounting the cabinet to the pole, connecting the signal and detectors, and excavation, backfilling, restoration, any necessary pole mounting hardware, electric service, or electrical inspection fees and will consider them incidental to this item of work. The Department will also not measure connecting the induction loop amplifiers, pedestrian, isolators, load switches, model 400 modem card; furnishing and installing electrical service conductors, specified conduits, anchors, meter base, fused cutout, fuses, ground rods, ground wires and will consider them incidental to this item of work.
<b>Subsection:</b>	723.04.22 Remove Signal Equipment.
<b>Revision:</b>	Replace the paragraph with the following: The Department will measure the quantity as a lump sum removal of signal equipment. The Department will not measure the return of control equipment and signal heads to the Department of Highways as directed by the District Traffic Engineer. The Department also will not measure the transportation of materials of the disposal of all other equipment and materials off the project by the contractor and will consider them incidental to this item of work.
<b>Subsection:</b>	723.04.28 Install Pedestrian Detector Audible.
<b>Revision:</b>	Replace the second sentence with the following: The Department will not measure installing sign R10-3e (with arrow) and will consider it incidental to this item of work.
<b>Subsection:</b>	723.04.29 Audible Pedestrian Detector.
<b>Revision:</b>	Replace the second sentence with the following: The Department will not measure furnishing and installing the sign R10-3e (with arrow) and will consider it incidental to this item of work.
<b>Subsection:</b>	723.04.30 Bore and Jack Conduit.
<b>Revision:</b>	Replace the paragraph with the following: The Department will measure the quantity in linear feet. This item shall include all work necessary for boring and installing conduit under an existing roadway. Construction methods shall be in accordance with Sections 706.03.02, paragraphs 1, 2, and 4.
<b>Subsection:</b>	723.04.31 Install Pedestrian Detector.
<b>Revision:</b>	Replace the paragraph with the following: The Department will measure the quantity as each individual unit installed and connected to pole/pedestal. The Department will not measure installing sign R 10-3e (with arrow) and will consider it incidental to this item of work.
<b>Subsection:</b>	723.04.32 Install Mast Arm Pole.
<b>Revision:</b>	Replace the second sentence with the following: The Department will not measure arms, signal mounting brackets, anchor bolts, or any other necessary hardware and will consider them incidental to this item of work.
<b>Subsection:</b>	723.04.33 Pedestal Post.
<b>Revision:</b>	Replace the second sentence with the following: The Department will not measure excavation, concrete, reinforcing steel, anchor bolts, conduit, fittings, ground rod, ground wire, backfilling, restoration, or any other necessary hardware and will consider them incidental to this item of work.

**Supplemental Specifications to the  
Standard Specifications for Road and Bridge Construction, 2012 Edition  
Effective with the September 27, 2013 Letting**

<b>Subsection:</b>	723.04.36 Traffic Signal Pole Base.															
<b>Revision:</b>	Replace the second sentence with the following: The Department will not measure excavation, reinforcing steel, anchor bolts, specified conduits, ground rods, ground wires, backfilling, or restoration and will consider them incidental to this item of work.															
<b>Subsection:</b>	723.04.37 Install Signal Pedestal.															
<b>Revision:</b>	Replace the second sentence with the following: The Department will not measure excavation, concrete, reinforcing steel, anchor bolts, specified conduits, fittings, ground rod, ground wire, backfilling, restoration, or any other necessary hardware and will consider them incidental to this item of work.															
<b>Subsection:</b>	723.04.38 Install Pedestal Post.															
<b>Revision:</b>	Replace the second sentence with the following: The Department will not measure excavation, concrete, reinforcing steel, anchor bolts, specified conduits, fittings, ground rod, ground wire, backfilling, restoration, or any other necessary hardware and will consider them incidental to this item of work.															
<b>Subsection:</b>	723.05 PAYMENT.															
<b>Revision:</b>	Replace items 04810-04811, 20391NS835 and, 20392NS835 under <u>Code</u> , <u>Pay Item</u> , and <u>Pay Unit</u> with the following:															
	<table style="width: 100%; border-collapse: collapse;"> <thead> <tr> <th style="text-align: left;"><u>Code</u></th> <th style="text-align: left;"><u>Pay Item</u></th> <th style="text-align: left;"><u>Pay Unit</u></th> </tr> </thead> <tbody> <tr> <td>04810</td> <td>Electrical Junction Box</td> <td>Each</td> </tr> <tr> <td>04811</td> <td>Electrical Junction Box Type B</td> <td>Each</td> </tr> <tr> <td>20391NS835</td> <td>Electrical Junction Box Type A</td> <td>Each</td> </tr> <tr> <td>20391NS835</td> <td>Electrical Junction Box Type C</td> <td>Each</td> </tr> </tbody> </table>	<u>Code</u>	<u>Pay Item</u>	<u>Pay Unit</u>	04810	Electrical Junction Box	Each	04811	Electrical Junction Box Type B	Each	20391NS835	Electrical Junction Box Type A	Each	20391NS835	Electrical Junction Box Type C	Each
<u>Code</u>	<u>Pay Item</u>	<u>Pay Unit</u>														
04810	Electrical Junction Box	Each														
04811	Electrical Junction Box Type B	Each														
20391NS835	Electrical Junction Box Type A	Each														
20391NS835	Electrical Junction Box Type C	Each														
<b>Subsection:</b>	813.04 Gray Iron Castings.															
<b>Revision:</b>	Replace the reference to "AASHTO M105" with "ASTM A48".															
<b>Subsection:</b>	813.09.02 High Strength Steel Bolts, Nuts, and Washers.															
<b>Number:</b>	A) Bolts.															
<b>Revision:</b>	Delete first paragraph and "Hardness Number" Table. Replace with the following: A) Bolts. Conform to ASTM A325 (AASHTO M164) or ASTM A490 (AASHTO 253) as applicable.															
<b>Subsection:</b>	814.04.02 Timber Guardrail Posts.															
<b>Revision:</b>	Third paragraph, replace the reference to "AWPA C14" with "AWPA U1, Section B, Paragraph 4.1".															
<b>Subsection:</b>	814.04.02 Timber Guardrail Posts.															
<b>Revision:</b>	Replace the first sentence of the fourth paragraph with the following: Use any of the species of wood for round or square posts covered under AWPA U1.															
<b>Subsection:</b>	814.04.02 Timber Guardrail Posts.															
<b>Revision:</b>	Fourth paragraph, replace the reference to "AWPA C2" with "AWPA U1, Section B, Paragraph 4.1".															
<b>Subsection:</b>	814.04.02 Timber Guardrail Posts.															
<b>Revision:</b>	Delete the second sentence of the fourth paragraph.															
<b>Subsection:</b>	816.07.02 Wood Posts and Braces.															
<b>Revision:</b>	First paragraph, replace the reference to "AWPA C5" with "AWPA U1, Section B, Paragraph 4.1".															

**Supplemental Specifications to the  
Standard Specifications for Road and Bridge Construction, 2012 Edition  
Effective with the September 27, 2013 Letting**

<b>Subsection:</b>	816.07.02 Wood Posts and Braces.
<b>Revision:</b>	Delete the second sentence of the first paragraph.
<b>Subsection:</b>	818.07 Preservative Treatment.
<b>Revision:</b>	First paragraph, replace all references to "AWPA C14" with "AWPA U1, Section A".
<b>Subsection:</b>	834.14 LIGHTING POLES.
<b>Revision:</b>	Replace the first sentence with the following: Lighting pole design shall be in accordance with loading and allowable stress requirements of the AASHTO Standard Specifications for Structural Supports for Highway Signs, Luminaires, and Traffic Signals, 2013-6th Edition with current interims.
<b>Subsection:</b>	834.14.03 High Mast Poles.
<b>Revision:</b>	<p>*Remove the second and fourth sentence from the first paragraph.</p> <p>*Replace the third paragraph with the following: Provide calculations and drawings that are stamped by a Professional Engineer licensed in the Commonwealth of Kentucky.</p> <p>*Replace paragraph six with the following: Provide a pole section that conforms to ASTM A 595 grade A with a minimum yield strength of 55 KSI or ASTM A 572 with a minimum yield strength of 55 KSI. Use tubes that are round or 16 sided with a four inch corner radius, have a constant linear taper of .144 in/ft and contain only one longitudinal seam weld. Circumferential welded tube butt splices and laminated tubes are not permitted. Provide pole sections that are telescopically slip fit assembled in the field to facilitate inspection of interior surface welds and the protective coating. The minimum length of the telescopic slip splices shall be 1.5 times the inside diameter of the exposed end of the female section. Use longitudinal seam welds as commended in Section 5.15 of the AASHTO 2013 Specifications. The thickness of the transverse base shall not be less than 2 inches. Plates shall be integrally welded to the tubes with a telescopic welded joint or a full penetration groove weld with backup bar.</p> <p>The handhole cover shall be removable from the handhole frame. One the frame side opposite the hinge, provide a mechanism on the handhole cover/frame to place the Department's standard padlock as specified in Section 834.25. The handhole frame shall have two stainless studs installed opposite the hinge to secure the handhole cover to the frame which includes providing stainless steel wing nuts and washers. The handhole cover shall be manufactured from 0.25 inch thick galvanized steel (ASTM A 153) and have a neoprene rubber gasket that is permanently secured to the handhole frame to insure weather-tight protection. The hinge shall be manufactured from 7-guage stainless steel to provide adjustability to insure weather-tight fit for the cover. The minimum clear distance between the transverse plate and the</p> <p>bottom opening of the handhole shall not be less than the diameter of the bottom tube of the pole but needs to be at least 15 inches. The handhole frame width shall be 0.4 times the diameter of the bottom tube.</p> <p>Provide products that are hot-dip galvanized to the requirements of either ASTM A123 (fabricated products) or ASTM A 153 (hardware items).</p>
<b>Subsection:</b>	834.16 ANCHOR BOLTS.
<b>Revision:</b>	Insert the following sentence at the beginning of the paragraph: The anchor bolt design shall follow the NCHRP Report 494 Section 2.4 and NCHRP 469 Appendix A Specifications.



**Supplemental Specifications to the  
Standard Specifications for Road and Bridge Construction, 2012 Edition  
Effective with the September 27, 2013 Letting**

<b>Subsection:</b>	834.17.01 Conventional.
<b>Revision:</b>	Add the following sentence after the second sentence: Provide a waterproof sticker mounted on the bottom of the housing that is legible from the ground and indicates the wattage of the fixture by providing the fist to numbers of the wattage.
<b>Subsection:</b>	834.21.01 Waterproof Enclosures.
<b>Revision:</b>	*Add the following sentence in the second paragraph in the thirteenth sentence: Provide a cabinet door with a louvered air vent, Filter-retaining brackets and an easy clean metal filter. *Replace sentence sixteen with the following: Use a 120-volt fixture and utilize a compact fluorescent or L.E.D. bulb (equivalent to 60 watt minimum).
<b>Subsection:</b>	835.07 Traffic Poles.
<b>Revision:</b>	Replace the first sentence of the first paragraph with the following: Pole diameter and wall thickness shall be calculated in accordance with the AASHTO Standard Specifications for Structural Supports for Highway Signs, Luminaires, and Traffic Signals, 2013-6th Edition with current interims.
<b>Subsection:</b>	835.07 Traffic Poles.
<b>Revision:</b>	*Replace the first sentence of the fourth paragraph with the following: Ensure transverse plats have a thickness $\geq 2$ inches. *Add the following sentence to the end of the fourth paragraph: The bottom pole diameter shall not be less than 16.25 inches.
<b>Subsection:</b>	835.07 Traffic Poles.
<b>Revision:</b>	Replace the second sentence of the fifth paragraph with the following: For anchor bolt design, pole forces shall be positioned in such a manner to maximize the force on any individual anchor bolt regardless of the actual anchor bolt orientation with the pole.
<b>Subsection:</b>	835.07 Traffic Poles.
<b>Revision:</b>	Replace the first and second sentence of the sixth paragraph with the following: The pole handhole shall be 25 inches by 6.5 inches. The handhole cover shall be removable from the handhole frame. On the frame side opposite the hinge, provide a mechanism on the handhole cover/frame to place the Department's standard padlock as specified in Section 834.25. The handhole frame shall have two stainless studs installed opposite the hinge to secure the handhole cover to the frame which includes providing stainless steel wing nuts and washers. The handhole cover shall be manufactured from 0.25 inch thick galvanized steel (ASTM 153) and have a neoprene rubber gasket that is permanently secured to the handhole frame to insure weather-tight protection. The hinge shall be manufactured from 7 gauge stainless steel to provide adjustability to insure a weather-tight fit for the cover. The minimum clear distance between the transverse plate and the bottom opening of the handhole shall not be less than the diameter of the bottom tube but needs to be at least 12 inches.
<b>Subsection:</b>	835.07 Traffic Poles.
<b>Revision:</b>	*Replace the first sentence of the last paragraph with the following: Provide calculations and drawings that are stamped by a Professional Engineer licensed in the Commonwealth of Kentucky. *Replace the third sentence of the last paragraph with the following: All tables referenced in 835.07 are found in the AASHTO Standard Specifications for Structural Supports for Highway Signs, Luminaires, and Traffic Signals, 2013-6th Edition with current interims.

**Supplemental Specifications to the  
Standard Specifications for Road and Bridge Construction, 2012 Edition  
Effective with the September 27, 2013 Letting**

<b>Subsection:</b>	835.07.01 Steel Strain Poles.
<b>Revision:</b>	Replace the second sentence of the second paragraph with the following: The detailed analysis shall be certified by a Professional Engineer licensed in the Commonwealth of Kentucky.
<b>Subsection:</b>	835.07.01 Steel Strain Poles.
<b>Revision:</b>	Replace number 7. after the second paragraph with the following: 7. Fatigue calculations should be shown for all fatigue related connections. Provide the corresponding detail, stress category and example from table 11.9.3.1-1.
<b>Subsection:</b>	835.07.02 Mast Arm Poles.
<b>Revision:</b>	Replace the second sentence of the fourth paragraph with the following: The detailed analysis shall be certified by a Professional Engineer licensed in the Commonwealth of Kentucky.
<b>Subsection:</b>	835.07.02 Mast Arm Poles.
<b>Revision:</b>	Replace number 7) after the fourth paragraph with the following: 7) Fatigue calculations should be shown for all fatigue related connections. Provide the corresponding detail, stress category and example from table 11.9.3.1-1.
<b>Subsection:</b>	835.07.03 ANCHORS.
<b>Revision:</b>	Add the following to the end of the paragraph: There shall be two steel templates (one can be used for the headed part of the anchor bolt when designed in this manner) provided per pole. Templates shall be contained within a 26.5 inch diameter. All templates shall be fully galvanized (ASTM A 153).
<b>Subsection:</b>	835.16.05 Optical Units.
<b>Revision:</b>	Replace the 3rd paragraph with the following: The list of certified products can be found on the following website: <a href="http://www.intertek.com">http://www.intertek.com</a> .
<b>Subsection:</b>	835.19.01 Pedestrian Detector Body.
<b>Revision:</b>	Replace the first sentence with the following: Provide a four holed pole mounted aluminum rectangular housing that is a compatible with the pedestrian detector.

## APPENDIX H

### Special Note for Mechanically Stabilized Earth Retaining Walls

# SPECIAL NOTE FOR MECHANICALLY STABILIZED EARTH RETAINING WALLS

## 1.0 DESCRIPTION

### 1.01 General and Experience Requirements:

The work under this section consists of designing, furnishing all materials and constructing Mechanically Stabilized Earth (MSE) retaining walls in accordance with the current Standard Specifications, this Special Note, in compliance with the lines and grades, dimensions and details shown on the project plans, and as directed by the Engineer.

The Contractor shall provide the MSE wall designer with a complete set of project plans and specifications and shall ensure that the wall design is compatible with all other project features that can impact the design and construction of the wall. The following terms are used in this specification for identification of various entities for which the Contractor shall be fully responsible:

Term	Entity
Wall Manufacturer	The entity contractually retained by the contractor to provide materials and construction services for an accepted MSE wall system as identified in Subsection 1.02.
Wall Designer	The entity contractually retained by the contractor to provide design of an accepted MSE wall system as identified in Subsection 1.02. The wall designer may be a representative of the wall manufacturer.
Department / Engineer	Refers to the Kentucky Transportation Cabinet representative and/or a designated consultant acting on behalf of KYTC.

### 1.02 Accepted Systems:

The contractor shall provide an MSE Wall System that uses inextensible reinforcement and reinforced concrete panels or modular block and is one of the pre-approved systems below. Inclusion of a system on this list does not relieve the Contractor and/or wall manufacturer of the contractual responsibility to satisfy all specific requirements herein and/or elsewhere in the contract documents.

- Reinforced Earth (Reinforced Earth and Retained Earth)
- Hilfiker RSE
- Tricon Retained Soil Wall System
- ISOGRID Retaining Wall System
- Keystone Keysystem I
- Sine Wall MSE Panel System
- Sanders Pre-Cast Concrete Systems

Heights and lengths of earth retaining walls may vary from, but shall not be less than, those shown on the plans. The height and length to be used for any system shall be the minimum for that system that will effectively retain the earth behind the wall for the loading conditions and the contours, profile, or slope lines shown on the plans, or on the approved working drawings, and in accordance with all relevant internal and external stability design criteria, but not more than the pre-approved height for the particular MSE wall system selected.

### **1.03 MSE Wall Design Engineer:**

Requirements for the Wall Designer's **MSE Wall Design Engineer** (who may be employed by the wall manufacturer or may be a consultant) are:

- Licensed Professional Engineer in the Commonwealth of Kentucky with a minimum of 5 years of geotechnical and/or structural engineering experience.
- Design and/or construction experience on at least five (5) MSE Walls and a minimum of 50,000 square feet of MSE Wall completed in the past five (5) years. Experience on a Reinforced Soil Slope may be substituted for one wall and up to 10,000 square feet.
- Design experience on at least three (3) MSE Walls and a minimum of 30,000 square feet of MSE Wall on highway infrastructure projects using the wall system that will be used on this project completed in the past five (5) years.
- Completion of at least 15 Professional Development Hours related to the design and/or construction of MSE Walls in the past five (5) years. This training may consist of attendance at a related short course, conference, seminar, workshop, or college course. Include documentation of this training with the submittal of the Design Engineer's credentials.

### **1.04 Wall Aesthetics:**

Wall aesthetics shall be as specified in the project documents and request for proposals.

### **1.05 Certifications:**

- (A) Certification of Design Parameters: See Subsection 2.01 herein specified.
- (B) Certification of Materials: See Subsections 3.04, 3.07, 3.09 & 3.10 herein specified.

### **1.5 QUALITY CONTROL:**

The Department will perform construction inspection for the MSE Walls. However, the Contractor will be required to proactively implement the quality control procedures described herein. All costs associated with MSE Wall Quality Control will be incidental to the cost of the wall.

#### **1.51 MSE Wall Quality Coordinator:**

The Contractor shall designate a MSE Wall Quality Coordinator who shall:

- have a minimum of 3 years of construction field experience,
- be responsible for ensuring that the Contractor's quality control procedures are implemented including maintaining and submitting the checklists required in Section 1.57, (but may have other duties and/or responsibilities),
- have sufficient authority to carry out quality coordinator responsibilities, and
- be in the field during MSE Wall construction.

#### **1.52 Mandatory MSE Wall Construction Training:**

The MSE Wall Designer or an approved appointee will provide training related to proper MSE Wall construction for Contractor and Department personnel. This training should occur after the contractor has selected the MSE Wall system and the Department has confirmed that the MSE Wall Design Engineer and Manufacturer's Technical Field Representative meet the specified requirements. The training will be conducted in the District by the Manufacturer's Technical Field Representative or an outside consultant meeting the experience requirements of the Manufacturer's Technical Field

Representative. The MSE Wall Construction Training is expected to last one full day. Department personnel who will attend will include project inspection personnel and may include other district and central office personnel. The following contractor personnel are required to attend:

- On-Site Supervisor in charge of MSE Wall construction
- MSE Wall Quality Coordinator
- At least one office management level person representing the MSE Wall contractor
- If the MSE Wall is to be constructed by a subcontractor, at least one management level representative (field or office) of the Prime Contractor
- Manufacturer's Technical Field Representative referenced in Section 1.55 herein

At least one week before the training begins, the Contractor shall submit a list of specific persons who plan to attend.

### **1.53 Quality Control Plan:**

The contractor shall submit a Quality Control Plan to the Engineer for review and acceptance which details measurements and documentation (including daily documentation checklists) that will be maintained by the Contractor during construction to assure consistency in meeting specification requirements. The Contractor shall coordinate the development of the Quality Control Plan with the MSE Wall System Manufacturer and the MSE Wall Design Engineer. The Quality Control Plan shall be submitted to the Engineer for acceptance at least four weeks before beginning MSE wall construction.

### **1.54 MSE Pre-Activity Meeting:**

A pre-activity meeting will be scheduled and shall occur after the Quality Control Plan has been submitted and accepted by the Engineer and no later than two (2) weeks prior to commencement of MSE wall construction activity. As a minimum, this meeting shall be attended by representatives of the Contractor and MSE Wall Sub-Contractor (including wall construction crew chiefs and MSE Wall Quality Coordinator), MSE Wall Manufacturer's Technical Field Representative, Department District personnel as designated by the Branch Manager for Project Delivery and Preservation, Central Office Construction, and Geotechnical Branch. No wall construction activity shall be performed until the contractor's final submittals have been approved as having satisfactorily resolved all review comments and the pre-activity meeting has been held.

### **1.55 Manufacturer's Technical Field Representative:**

The MSE Wall System Manufacturer shall provide a technical field representative to provide assistance to the MSE Wall Contractor. The requirements for the **Manufacturer's Technical Field Representative** are:

- At minimum, an associate's or bachelor's degree with a major in a technical or scientific field such as engineering, engineering or construction technology, geology, physics, mathematics, etc.
- A minimum of five (5) years of technical experience related to engineering and/or construction.
- Construction experience on at least five (5) MSE Walls and a minimum of 50,000 square feet of MSE Wall completed in the past five (5) years. Experience on a Reinforced Soil Slope may be substituted for one wall and up to 10,000 square feet.
- Construction experience on at least three (3) MSE Walls and a minimum of 30,000 square feet of MSE Wall on highway infrastructure projects using the wall system that will be used on this project completed in the past five (5) years.

- Completion of at least ten (10) Professional Development Hours related to the design and/or construction of MSE Walls in the past five (5) years. This training may consist of attendance at a related short course, conference, seminar, workshop, or college course. Include documentation of this training with the submittal of the Technical Field Representative's credentials.

At least four weeks before beginning MSE wall construction, the Contractor shall submit documentation that the Technical Field Representative meets the above requirements.

The minimum required duties of the Manufacturer's Technical Field Representative are:

- Participate in the mandatory training referenced in Section 1.52 herein.
- Participate in the preparation of the Quality Control Plan referenced in Section 1.53 herein.
- Attend the MSE Pre-Activity Meeting referenced in Section 1.54 herein.
- Ensure that the contractor obtains all "Certificates of Analysis" required in Section 3.0 (Materials Requirements) of this Special Note.
- Review all "Certificates of Analysis" and supporting documentation and provide written documentation to the Contractor and Engineer that the reviews have been completed and that all materials meet the specified requirements.
- Review all Supervisor Checklists described in Section 1.57 herein.
- Be present at a minimum, during construction of the initial 10-foot height of the full length of wall for each wall system. Additionally the representative shall be present for the initial 10-foot height of the full length of wall for each wall system as constructed by each additional contractor, and as called upon thereafter by the Engineer, to assist the contractor and Engineer at no additional cost to the Agency.
- After each on-site visit, the Contractor is required to submit a letter to the Engineer written by the Manufacturer's Technical Field Representative documenting the observations of each visit with documentation that the MSE Wall Design Engineer has reviewed the letter.
- The manufacturer's technical field representative may recommend field changes subject to the approval of the MSE Wall Design Engineer and the Department. Any such changes shall be documented in writing within 24 hours of the approved changes. This written document shall be sealed by the MSE Wall Design Engineer prior to implementation of the changes.
- The Department reserves the right to discuss matters pertaining to this project directly with the technical field representative and to require the Contractor to call the technical field representative to the site for assistance at no additional cost to the Department if, in the opinion of the Engineer, the Contractor is not satisfactorily complying with the plans and specifications.

### **1.56 Certificates of Analysis:**

The Contractor will be responsible for performing and/or subcontracting all testing required to produce the Certificates of Analysis required in Section 3.0 (Materials Requirements) of this Special Note and for submitting the Certificates to the Engineer as required.

### **1.57 Checklists:**

The Contractor's MSE Wall On-Site Supervisor and MSE Wall Quality Coordinator shall complete and both sign the checklists below and submit them to the Engineer with copies to the Manufacturer's Technical Field Representative. The first three of these checklists can be found in FHWA Publication No. FHWA-NHI-10-025 "*Design and Construction of Mechanically Stabilized Earth Walls and Reinforced Soil Slopes – Volume II*", dated November 2009 (these tables are located in the appendix of this document).

<b>Checklists</b>	
<b>Checklist Title</b>	<b>Submittal Requirements</b>
Checklist for Drawing Review (FHWA Table 11-2)	At least two weeks before starting MSE wall construction
Checklist for Specification Compliance (FHWA Table 11-3)	Weekly
Checklist for Construction (FHWA Table 11-5)	Weekly
Quality Control Documentation (Quality Control Plan)	Daily

**1.58 MSE Wall Design Engineer:**

The MSE Wall Design Engineer will be required to play an active role in the construction of the MSE walls and to be available to answer any questions that may arise during construction. Specifically, the MSE Wall Design Engineer is required to:

- Assist the Contractor and Manufacturer’s Technical Field Representative with preparing the Quality Control Plan referenced in Section 1.53 herein.
- Make at least one site visit (4 hour minimum) while the Contractor is installing panels and reinforced fill material during the first 10 working days of panel and reinforced fill installation
- Review documentation of the Manufacturer’s Technical Field Representative’s site visits.

Additionally, the Design Engineer is required to attend the MSE Wall Construction Training and MSE Pre-Activity Meeting.

**2.0 DESIGN SUBMITTALS (WORKING DRAWINGS AND DESIGN CALCULATIONS):**

**2.01 Submittals:**

**(A) General:**

Design calculations and working drawings clearly showing conformance with the current Standard Specifications; AASHTO LRFD Bridge Design Specifications, current edition; KYTC Geotechnical Manual and project requirements shall be submitted for review. The format for the working drawings shall be in accordance with the Division of Structural Design's Guidance Manual. The first sheet shall be a title sheet.

Working drawings and design calculations shall be sealed by a licensed Professional Engineer in the Commonwealth of Kentucky. The MSE wall designer/supplier shall document on the working drawings all assumptions made in the design. The following statement shall be included near the P.E. seal on the first sheet of the working drawings: “All design assumptions are validated through notes or details on these drawings.”

The Department assumes no responsibility for errors or omissions in the working drawings. Acceptance of the final working drawings submitted by the contractor shall not relieve the contractor of any responsibility under the contract for the successful completion of the work. Construction of the wall shall not commence until the contractor receives a written Notification to Begin MSE Wall Construction from the Engineer which will be issued once the complete wall package (drawings, calculations and



construction procedures) is accepted. Fabrication of any of the wall components before the written Notification to Begin MSE Wall Construction shall be at the sole risk of the Contractor.

A Certificate of Analysis for the Reinforced Fill Material (See Sections 3.05 and 3.07 herein) may be required prior to final acceptance of the MSE Wall design.

**(B) Review Submittals:**

All review submittals shall be submitted electronically in pdf format through the Contractor to the Project Resident Engineer. The Project Resident Engineer shall forward the plans, calculations, and working drawings to the Department. Submittals may be directly emailed to applicable reviewers with the permission of the Contractor and Resident Engineer provided that the Contractor and Resident Engineer receive email copies of the submittals. Contact the Department before beginning any work on the wall designs and construction plans.

The submittals required shall include working drawings, the Contractor's and MSE Wall supplier's construction procedures, supporting design calculations, verification of experience, and a transmittal letter. The transmittal letter shall only list the documents included in the submittal. No technical information shall be included in the transmittal letter.

Working drawings, design calculations and MSE supplier's construction procedures modified as necessary by the contractor and Wall Designer for site-specific conditions shall be submitted to the Engineer for review. The Engineer shall have 30 calendar days after receiving the six complete sets to finish a review. The revised package shall be resubmitted to the Engineer for review. The Engineer shall have 15 calendar days to complete this review. This review process shall be repeated until the entire submittal is accepted by the Engineer. Additional time required by the Department to review resubmissions shall not be cause for increasing the number of contract working days. The additional work required by the contractor to provide resubmissions shall be at no cost to the Department.

The Department reserves the right to require the contractor to verify that the Reinforced Wall Fill Material meets all applicable requirement before final acceptance of the design.

**(C) Final Submittals:**

All final wall tracings, with drawing number, shall be submitted on 3 mil, or thicker, 22" X 36" mylar film. The final mylar tracings of the accepted working drawings submitted to the Division of Structural Design shall be dated, sealed, and signed on Sheet 1 by the licensed Professional Engineer performing the work. Nine copies of the accepted working drawings shall be submitted.

**2.02 Working Drawings:**

The contractor shall submit complete working drawings and specifications for each installation of the system. Working drawings shall include the following at a minimum:

- (1) Layout of the wall including plan and elevation views;
- (2) All design parameters and assumptions including design life;
- (3) Existing ground elevations and utilities impacted by the wall, and those that should be field verified by the contractor, for each location;
- (4) Complete details of all elements and component parts required for the proper construction of the system at each location and any required accommodations for drainage systems, foundation subgrades or other facilities shown on the contract documents;
- (5) The working drawing submittal shall clearly detail any special design requirements, if applicable. These special design requirements may include, but are not limited to: structural frames to place

reinforcements around obstructions such as deep foundations and storm drain crossings, drainage systems, placement sequence of drainage and unit core fill with respect to reinforced (structure) fill behind a wall face using modular block facing units, guardrail post installation, scour protection, foundation subgrade modification, all corner details (acute, obtuse and 90 degrees), slip joints, joint details of MSE walls with other cast-in-place structures, wedges, shims and other devices such as clamps and bracing to establish and maintain vertical and horizontal wall facing alignments;

- (6) A complete listing of components and materials specifications; and
- (7) Other site-specific or project specific information required by the contract.

### **2.03 MSE Wall Design:**

#### **(A) General:**

The working drawings shall be supplemented with all design calculations for the particular installation as required herein. Installations that deviate from the accepted design (by the Contractor's MSE Wall Design Engineer) shall be accompanied by supporting stability (internal; external; and global/overall and/or compound if required in the project documents) calculations of the proposed structure as well as supporting calculations for all special details not contained in the accepted design. The MSE wall designer/supplier shall note all deviations of the proposed wall design from the accepted design.

The proposed design shall satisfy the design parameters shown on the project plans and listed in this Special Note, and comply with the design requirements of AASHTO LRFD Bridge Design Specifications, current edition and the KYTC Geotechnical and Bridge Design Guidance Manuals. Unless otherwise specified in the contract, all structures shall be designed to conform to the requirements shown in Table 1 and other requirements specified herein.

If the designer uses software other than MSEW, a minimum of one analysis corresponding to the most critical design case for each MSE wall shall be submitted using MSEW software. Sample hand calculations containing a sketch, all external analysis for the design case, and internal analyses for a minimum of three reinforcement levels shall also be submitted for the most critical design case for each MSE wall.

**Table 1 - MSE Wall Design Criteria and Parameters**

Design Life	100 years
Friction angle of granular retained backfill ( <u>where required</u> )	36°
Friction angle of MSE reinforced fill material	34° *
Total Unit weight of granular retained backfill	120 pcf
Total Unit weight of MSE reinforced fill material	120 pcf **
Minimum reinforcement length	Greater of 8 ft. or 0.7 times design height
Friction angle for sliding calculation (through reinforced fill)	34° *
Resistance factor for sliding	As specified in AASHTO LRFD Bridge Design Specifications
Wall Eccentricity	Verify as specified in AASHTO LRFD Bridge Design Specifications, current edition
Bearing Resistance Factor	As specified in AASHTO LRFD Bridge Design Specifications
Surcharge Loading (due to vehicle loading behind the walls)	As specified in AASHTO LRFD Bridge Design Specifications
Minimum top of leveling pad embedment	2 ft. below final grade or as specified by the Geotechnical Report

\* For internally reinforced fill material, a minimum friction angle of 34 degrees shall be substantiated by laboratory tests discussed in Subsection 3.05(D). If the measured friction angle in laboratory tests as per Subsection 3.05(D) is greater than 34 degrees and the fill material is well-graded according to the Unified Soil Classification System (USCS), then the design friction angle may be increased up to a maximum of 38 degrees. See Table 5.

\*\* The Total Unit Weight of the reinforced fill material shall be substantiated by laboratory tests discussed in Subsection 3.05(F). If the Total Unit Weight (i.e. SSD Bulk Density) obtained from laboratory tests as per Subsection 3.05(F) varies by more than +/- 5.0 pcf from the design value, then the design must be adjusted accordingly or reinforced fill material falling within this range must be used. See Table 5.

“H” is the design height of the wall and is defined as the difference in elevation from the finished grade at the top of wall and the top of leveling pad. The top of the leveling pad shall always be below the minimum embedment reference line as indicated on the plans for that location. The length of reinforcement, “L”, is measured from the backface of the wall facing unit. If applicable, the length of grid type reinforcement is measured from the backface of the wall to the last full transverse member. If applicable, the total base length for modular block facing units, B<sub>T</sub>, as measured from the front face of the wall is the length L as defined above plus the width of the modular block unit (the horizontal dimension of the block unit measured perpendicular to the wall face).

**(B) Subsurface Drainage Systems:**

Walls shall be provided with subsurface drainage measures as shown on the project plans and specifications. As a minimum, an underdrain system shall be provided for leading subsurface and surface water away from the reinforced fill material and outside the limits of the wall. Geocomposite

drains, if used for subsurface drainage, shall be in accordance with Section 845 of the current Standard Specifications.

**(C) Obstructions in Reinforced Fill:**

**(1) General:**

Where obstructions, such as deep foundations or storm drains crossings, are located in the reinforced fill material zone, cutting of reinforcements to avoid obstructions shall not be permitted. A minimum offset of one diameter but not less than three (3) feet shall be maintained between the face of any pipe crossings and the back face of retaining wall panels. A minimum clearance of three (3) feet shall be maintained between the face of any other obstruction and the back face of retaining wall panels.

**(2) Horizontal Deflection of Reinforcements:**

In the horizontal plane at a reinforcing level, a deviation up to fifteen (15) degrees from the normal to the face of the wall may be allowed for strip reinforcement and bolted connection. This deviation is herein referred to as the splay angle. Grid reinforcements may not be splayed, unless connection has been specifically fabricated to accommodate a splay and connection detail has been approved by the Department. If used, the splay in grid reinforcement is limited to fifteen (15) degrees. For obstructions that cannot be accommodated with splayed reinforcement, structural frames and connections shall be required, and shall be designed in accordance with the AASHTO LRFD Bridge Design Specifications, current edition. The structural frame design shall be such that bending moments are not generated in the fill reinforcement or the connection at the wall face. The design, along with supporting calculations, shall be included in the working drawings.

**(3) Vertical Deflection of Reinforcements:**

Vertical deflection of the reinforcement to avoid obstructions such as utilities along the wall face shall be limited to a maximum of 15 degrees from normal to face of wall. Bends in the reinforcement shall be smooth and gradual to ensure that galvanization remains intact.

**(D) Hydrostatic Pressures:**

As determined by the Designer and/or as noted on the plans, for walls potentially subject to inundation, such as those located adjacent to rivers, canals, detention basins or retention basins. Effective unit weights shall be used in the calculations for internal and external stability beginning at levels just below the equivalent surface of the pressure head line. Where the wall is influenced by water fluctuations, the wall shall be designed for rapid drawdown conditions which could result in differential hydrostatic pressure.

**(E) Acute Angle Corners:**

Wall corners with an included angle of less than 70 degrees shall be designed for bin-type lateral pressures for the extent of the wall where the full length of the reinforcement cannot be installed without encountering a wall face. Acute angle corner structures shall not be stand-alone separate structures. Computations shall be provided that demonstrate deformation compatibility between the acute angle corner structure and the rest of the MSE wall. Full-height vertical slip joints shall be provided at the acute angle corner and after the last column of panels where full length of the reinforcements can be placed. The soil reinforcement attached to the slip joints shall be oriented perpendicular to the slip joint panels and shall be the full design length. Special connection and compaction details shall be provided

on the working drawings.

**(F) Spacing of Metallic Reinforcement for Flexible Face Wall Systems:**

Permanent Flexible Face Wall Systems are not allowed.

**(G) Fill Reinforcement for Modular Block Wall Systems:**

The reinforcement lengths and percent coverage at a given reinforcement level shall be in accordance with the plans. All reinforcement shall be positively connected to the modular block facing units that is capable of resisting 100% of the maximum tension in the reinforcements at any level within the wall. Detailed documentation for connection strength shall be submitted as noted in Subsection 3.10. The vertical spacing of the reinforcement for walls with modular block facing units shall be as follows:

1. The first (bottom) layer of reinforcement shall be no further than 16 inches above the top of the leveling pad.
2. The last (top) layer of reinforcement shall be no further than 20 inches on the average below the top of the uppermost MBW unit.
3. The maximum vertical spacing between layers of adjacent reinforcement shall not exceed 32 inches. For walls deriving any part of their connection capacity by friction the maximum vertical spacing of the reinforcement should be limited to two times the block depth (front face to back face) to assure construction and long-term stability. The top row of reinforcement should be one-half the vertical spacing.

**(H) Initial Batter of Wall:**

The initial batter of the wall, both during construction and upon completion, shall be within the vertical and horizontal alignment tolerances included in this Special Note. The initial batter of the wall panels at the start of construction and the means and methods necessary to achieve the batter shall be provided on the working drawings. Subject to Engineer's approval, the initial batter of the wall panels may be modified at the start of construction by the manufacturer's field representative based on the evaluation of the reinforced fill material selected by the contractor. Any such changes shall be documented in writing within 24 hours of the approved changes. This written document shall be sealed by the manufacturer's design engineer who is a licensed Professional Engineer in the Commonwealth of Kentucky. Details of the wedges or shims or other devices, such as clamps and external bracing used to achieve or maintain the wall batter, and the details for removal of temporary wedges or shims shall be as shown on the working drawings and/or accompanying construction manual. Permanent shims shall comply with the design life criteria, and shall maintain the design stress levels required for the walls.

**(I) Bridge Abutment Design Considerations:**

Shallow Bridge Foundations supported by MSE wall systems are not allowed. All bridge loads must be supported by deep foundations.

**3.0 MATERIAL REQUIREMENTS:**

The contractor shall furnish the Engineer with Certificates of Analysis documenting that all materials meet the requirements herein.

**3.01 Precast Concrete Elements:**

Precast concrete shall attain a minimum 28-day compressive strength of 4,000 psi unless a higher strength is specified by the wall supplier. The concrete shall be air entrained containing  $5.5 \pm 1.5\%$  entrained air at the time the concrete is placed in the forms. A proposed mix design shall be submitted. Prior to casting, all embedded components shall be set in place to the dimensions and tolerances designated in the plans and specifications. Wall aesthetics shall be in accordance with project plans, special notes, and/or other applicable contract documents.

**(A) Concrete Testing and Inspection:**

Precast concrete elements shall be subjected to compressive strength testing and inspected for dimensional tolerances and surface conditions. Panels delivered to the site without Department approval will be rejected.

**(B) Casting:**

Precast concrete face panels shall be cast on a horizontal surface with the front face of the panel at the bottom of the form. Connection hardware shall be set in the rear face. The concrete in each precast concrete panel shall be placed without interruption and shall be consolidated by deploying an approved vibrator, supplemented by such hand tamping as may be necessary to force the concrete into the corner of the forms, and to eliminate the formation of stone pockets or cleavage planes. Form release agents shall be used on all form faces for all casting operations.

The contractor shall advise the Engineer of the starting date for concrete panel casting at least 14 calendar days prior to beginning the operation if the casting operation is within the State, or 21 calendar days if the casting operation is outside the State.

**(C) Finish:**

**(1) Non-Exposed Surfaces:**

Rear faces of precast concrete panels shall be a face floated surface finish and screeded to eliminate open pockets of aggregate and surface distortions in excess of 1/4 inch.

**(2) Exposed Surfaces:**

The type of finish required on exposed surfaces shall be as shown in the plans.

**(a) Exposed Aggregate Finish:**

- (1) Prior to placing concrete, a set retardant shall be applied to the casting forms in accordance with the manufacturer's instructions.
- (2) After removal from the forms and after the concrete has set sufficiently to prevent its dislodging, the aggregate shall be exposed by a combination of brushing and washing with clear water. The depth of exposure shall be between 3/8 inch and 1/2 inch.
- (3) An acrylic resin sealer consisting of 80 percent thinner and 20 percent acrylic solids by weight shall be applied to the exposed aggregate surface at a rate of one (1) gallon per 250 square feet.

**(b) Concrete Panel Finish:**

Concrete panel finish shall be in accordance with the plans and specifications. A sample of the proposed finish consisting of four full-sized panels shall be fabricated for inspection by the Engineer. Fabrication of the remaining panels is not authorized until the Engineer has inspected the sample panels and approved the finish as acceptable.

**(D) Tolerances:**

Connection device placement shall be within  $\pm 1$  inch of the dimensions shown on the drawings. Panel squareness as determined by the difference between the two diagonals shall not exceed  $\frac{1}{2}$  inch.

**(E) Identification and Markings:**

The date of manufacture, the production lot number, and the piece mark shall be inscribed on a non-exposed surface of each element.

**(F) Handling, Storage and Shipping:**

All panels shall be handled, stored, and shipped in such a manner to eliminate the dangers of chipping, discoloration, cracks, fractures, and excessive bending stresses. Panels in storage shall be supported in firm blocking to protect panel connection devices and the exposed exterior finish. Storing and shipping shall be in accordance with the manufacturer's recommendations.

**(G) Compressive Strength:**

Precast concrete elements shall not be shipped or placed in the wall until a compressive strength of 3,400 pounds per square inch has been attained. The facing elements shall be cast on a flat and level area and shall be fully supported until a compressive strength of 1,000 pounds per square inch has been attained.

**(H) Precast Concrete Panel Joints:**

**(1) General:**

Where the wall wraps around an inside corner, a corner block panel shall be provided with flange extensions that will allow for differential movement without exposing the panel joints. The back face of vertical and horizontal joints shall be covered with geotextile filter. Joint filler, bearing pads, and geotextile filter shall be as recommended by the wall manufacturer and shall meet the requirements shown on the approved working drawings.

If required, as indicated on the plans, flexible open-cell polyurethane foam strips shall be used for filler for vertical joints between panels, and in horizontal joints where pads are used.

All joints between panels on the back side of the wall shall be covered with a Type IV geotextile fabric meeting the requirements of Section 843 of the current Standard Specifications. The minimum width shall be one (1) foot.

**(2) Bearing Pads:**

All horizontal and diagonal joints between panels shall include bearing pads. Bearing pads shall meet or exceed the following material requirements:

- Preformed EPDM (Ethylene Propylene Diene Monomer) rubber pads conforming to ASTM D 2000 Grade 2, Type A, Class A with a Durometer Hardness of 70.
- Preformed HDPE (High Density Polyethylene) pads with a minimum density of 0.946 grams per cubic centimeter in accordance with ASTM D 1505.

The stiffness (axial and lateral), size, and number of bearing pads shall be determined

such that the final joint opening shall be  $\frac{3}{4} \pm \frac{1}{8}$  inch unless otherwise shown on the plans. The MSE wall designer shall submit substantiating calculations verifying the stiffness (axial and lateral), size, and number of bearing pads assuming, as a minimum, a vertical loading at a given joint equal to 2 times the weight of facing panels directly above that level. As part of the substantiating calculations, the MSE wall designer shall submit results of certified laboratory tests in the form of vertical load-vertical strain and vertical load-lateral strain curves for the specific bearing pads proposed by the MSE wall designer. The vertical load-vertical strain curve should extend beyond the first yield point of the proposed bearing pad.

### **3.02 Steel Components:**

#### **(A) Galvanization:**

Fill reinforcement steel shall be hot-dip galvanized in accordance with AASHTO M 111 (ASTM A123). Connection hardware steel can be galvanized by hot-dipping or other means, provided the method satisfies the requirements of AASHTO M 111 (ASTM A123). A minimum galvanization coating of 2.0 oz/ft<sup>2</sup> (605 g/m<sup>2</sup>) or 3.4 mils (85 μm) thickness is required. Fill reinforcement steel shall be adequately supported while lifting and placing such that the galvanization remains intact. Steel members with damaged (peeled) galvanization shall be repaired according to ASTM A780 and as specified in approved working drawings, at no additional cost to the Department.

#### **(B) Metallic Reinforcing Strips and Tie Strips:**

Reinforcing strips shall be hot-rolled from bars to the required shape and dimensions. The strips' physical and mechanical properties shall conform to the requirements of ASTM A572, Grade 65 minimum.

Tie strips shall be shop fabricated of hot-rolled steel conforming to the requirements of ASTM A1101, Grade 50 minimum. The minimum bending radius of the tie strips shall be  $\frac{3}{8}$  inch. Galvanization shall be applied after the strips are fabricated, inclusive of punch holes for bolts as shown on approved drawings.

#### **(C) Metallic Reinforcing Mesh:**

Reinforcing mesh shall be shop fabricated of cold-drawn steel wire conforming to the requirements of AASHTO M 32, and shall be welded into the finished mesh fabric in accordance with AASHTO M 55. Galvanization shall be applied after the mesh is fabricated. A minimum galvanization coating of 2.0 oz/ft<sup>2</sup> (605 g/m<sup>2</sup>) or 3.4 mils (85 μm) thickness is required.

#### **(D) Connector Pins:**

Connector pins and mat bars shall be fabricated and connected to the fill reinforcement mats as shown in the approved working drawings. Connector bars shall be fabricated of cold drawn steel wire conforming to the requirements of AASHTO M 32.

#### **(E) Welded Wire Fabric:**

All welded wire fabric shall conform to the requirements of AASHTO M 32, AASHTO M 55, and the approved working drawings. Welded wire fabric shall be galvanized in conformance with the requirements of ASTM A123.



**(F) Fasteners:**

Connection hardware shall conform to the requirements shown in the approved working drawings. Connection hardware shall be cast in the precast concrete panels such that all connectors are in alignment and able to transfer full and even load to the fill reinforcement. Once the reinforcement is connected to the panel, the amount of slack shall not exceed 1/8 inch between the connector and the reinforcement during field installation. (If wedges are to be used to remove slack, the size, shape, and installation procedure with illustrations shall be included on the drawings and in the construction procedures.) Fasteners shall be galvanized and conform to the requirements of AASHTO M 164 or equivalent.

**3.03 Geosynthetic Reinforcement:**

Geosynthetic fill reinforcement is not allowed.

**3.04 Certificate of Analysis for Fill Reinforcements:**

For metallic wall reinforcement, a mill test report containing the ultimate tensile strength for the fill reinforcement shall be included in the certification. For metallic wall reinforcement, a mill test report containing the galvanization coverage shall be included in the certification. For metallic mesh wall reinforcement, a mill test report containing the ultimate weld strength for the fill reinforcement shall be included in the certification.

**3.05 Reinforced Wall Fill Material:**

Provide internally reinforced wall fill material consisting of quarry-processed limestone from a Department-approved quarry meeting all applicable general requirements of Section 805 of the Standard Specifications, current edition, and requirements herein. Provide material meeting the specific requirements for “Reinforced Fill Material” in Section 805 of the Standard Specifications, current edition, defined as “Non-Erodible” according to Section 805, and meeting all other requirements herein. Approval of the material source by the Department is required prior to beginning MSE wall construction. The reinforced wall fill material will be wrapped in Type IV Geotextile Fabric.

**(A) General:**

Reinforced wall fill material shall be free of shale, organic matter, mica, gypsum, smectite, montmorillonite, or other soft poor durability particles. No salvaged material, such as asphaltic concrete millings or Portland Cement Concrete rubble, etc., will be allowed.

**(B) Soundness and Shale:**

The reinforced fill material shall have a soundness loss of 30 percent or less when tested in accordance with AASHTO T104 using a magnesium sulfate solution with a test duration of four cycles. Alternatively, the material shall have a soundness loss of 15 percent or less when tested in accordance with AASHTO T104 using a sodium sulfate solution with a test duration of five cycles. A maximum of 2.0% shale is permitted as determined by KM 64-604.

**(C) Gradation:**

Gradations will be determined per AASTHO T27 and shall be in accordance with Table 2, unless otherwise specified.

**Table 2  
REINFORCED FILL GRADATION REQUIREMENTS**

Sieve Size	Percent Passing
4 inch	100
2 inch	40 – 90
No. 4	0 - 10
No. 200	0 – 5

This is the same gradation as required in Section 805.11 of the Standard Specifications except the requirement for the 2 inch sieve has been added.

Size # 23 in the Standard Specifications falls within these gradation limits.

**(D) Internal Friction Angle Requirement:**

The reinforced wall fill material shall exhibit an effective (drained) angle of internal friction of not less than 34 degrees, as determined by performing a Direct Shear Test in accordance with AASHTO T236 or ASTM D3080. A minimum of three (3) points (i.e. three normal stresses) is required to constitute a complete test.

The direct shear test shall be performed on the portion finer than the 1-inch sieve. In order to comply with the test method, a minimum 12-inch diameter circular box or minimum 12-inch square box is required. The sample shall be compacted directly in the shear device at the saturated surface dry (SSD) condition and in general accordance with the rodding procedure in AASHTO T-19.

**(E) Electrochemical Requirements:**

The reinforced wall fill material shall meet the electrochemical requirements of Table 3.

**Table 3  
ELECTROCHEMICAL REQUIREMENTS FOR METALLIC REINFORCEMENTS**

Characteristic	Requirement	Test Method
Resistivity	> 3,000 ohm-cm	AASHTO T-288
pH	5.0 to 10.0	AASHTO T-289
Chlorides	< 200 ppm	ASTM D4327
Sulfates	< 1000 ppm	ASTM D4327
Organic Content	< 1.0 %	AASHTO T-267

\* If the resistivity is greater or equal to 5,000 ohm-cm, the chloride and sulfate requirements may be waived.

**Table 4 – VACANT**

**(F) Saturated Surface Dry (SSD) Bulk Density:**

The Bulk Density of the Reinforced Fill Material shall be obtained in accordance with AASHTO T19. The Bulk Density at the oven-dry condition shall then be corrected using the Absorption determined according to AASHTO T-85 to determine the SSD Bulk Density, which shall be within +/- 5.0 pcf of the design total unit weight of MSE reinforced fill material or the design shall be adjusted. (See Table 1.)

**(G) Limits of Reinforced Wall Fill Material:**

The reinforced fill material shall extend to at least one (1) foot beyond the free end of the reinforcement. If applicable, back-to-back walls wherein the free ends of the reinforcement of the two walls are spaced apart less than or equal to one-half the design height of the taller wall, reinforced wall fill material shall be used for the space between the free ends of the reinforcements as well. The design height of the wall is defined as the difference in elevation between finished grade at top of wall and the top of leveling pad. The top of the leveling pad shall always be below the minimum embedment reference line as indicated on the plans for the location under consideration.

**3.06 Granular Embankment for Foundation and Retained Backfill:**

Provide granular foundation material and granular external retained backfill consisting of “Granular Embankment” meeting the material requirements of Section 805 in the current edition of the Standard Specifications and defined as “Non-Erodible” according to Section 805. If required by design, the extent of the granular foundation material and granular external retained backfill shall be shown in the Geotechnical Notes. Contrary to the Standard Specifications, no natural sand is permitted. Also contrary to the Standard Specifications, the maximum size limit for “Granular Embankment” is 4 inches where shown in the Geotechnical Sheets. Approval of the material source by the Department is required prior to beginning placement of this material.

**3.07 Sampling & Testing of Reinforced Wall Fill and Granular Embankment Materials**

**(A) Reinforced Wall Fill:**

To obtain source approval, the contractor shall furnish the Engineer with an 80-pound representative sample of the reinforced wall fill material and a Certificate of Analysis containing results of all tests referenced in Table 5 at least four weeks prior to beginning construction of the MSE wall.

During construction, the reinforced fill material shall be sampled and tested by the Engineer for acceptance and quality control testing. A new sample and Certificate of Analysis shall be provided any time the material and/or source changes.

**Table 5 - Sampling Frequency for Reinforced Wall Fill Material**

Function	Tests	Frequency
----------	-------	-----------

Source Approval Testing by Contractor and/or its Consultant(s)	Soundness (AASHTO T104)* % Shale (KM 64-604)* Gradation (AASHTO T27)* Direct Shear (AASHTO T236 or ASTM D3080)* Organic Content (AASHTO T267)* SSD Bulk Density (AASHTO T19 & T85)* Resistivity (AASHTO T288)** pH (AASHTO T289)** Chlorides and Sulfates (ASTM D4327)**	At least four (4) weeks prior to beginning MSE wall construction and once per material change and/or change in source.  Except for Direct Shear, one test is valid for up to 10,000 ft <sup>2</sup> of MSE wall area if there is no material change or change in source. ****  Generally, only one Direct Shear test is required unless there is a change in material, source, or gradation.
Acceptance and Quality Control Testing by Department	Gradation (AASHTO T27) % Shale (KM 64-304) At the discretion of the Engineer.	One per 2,000 cubic yards at job site. (A change of more than +/- 5.0 percent passing any sieve size <u>will</u> require additional SSD Bulk Density testing and <u>may</u> require additional Direct Shear testing, both by the Contractor.)
	Any other applicable requirements of Section 805 of the current Standard Specifications	As required by the current Materials Field Sampling and Testing Manual, Standard Specifications, and/or other Department policy.
<p>* The laboratory performing these tests must be accredited by the AASHTO Materials Reference Laboratory (AMRL) for the tests they perform. AMRL accreditation for AASHTO T104 &amp; T27 is required to perform KM 64-604.</p> <p>** Although accreditation for the specific test methods may not be available, the laboratory performing these tests must be accredited or certified by one of the organizations below. A laboratory's accreditation or certification status does not relieve the laboratory of its responsibility to perform the tests in accordance with the specified methods.</p> <ul style="list-style-type: none"> <li>• AMRL - Soil and/or Aggregate (Resistivity and pH only)</li> <li>• American Association for Laboratory Accreditation (A2LA) - Chemical and/or Environmental</li> <li>• Kentucky Division of Water - Drinking Water Chemical Analyses</li> </ul> <p>The Contractor may consult the Geotechnical Branch to ensure that a lab is accredited or certified.</p> <p>**** e.g. 1 to 10,000 ft<sup>2</sup> of wall requires 1 test, 10,001 to 20,000 ft<sup>2</sup> requires 2 tests, etc.</p>		

**(B) Granular Embankment Material for Foundation and Retained Backfill:**

To obtain source approval, the contractor shall furnish the Engineer with an 80-pound representative sample of the Granular Embankment material and a Certificate of Analysis at least four weeks prior to beginning Granular Embankment construction.

<b>Table 6</b>	
<b>Sampling Frequency for Granular Embankment for Foundation and Retained Backfill</b>	
<b>Function</b>	<b>Frequency</b>
Source Approval	At least four weeks prior to beginning granular embankment construction and once per material change and/or change in source.
Acceptance and Quality Control	In accordance with standard procedures for "Granular Embankment".

**3.08 Cast-in-Place Concrete:**

Cast-in-place concrete shall be Class A, except that the leveling pads shall be Class B, both in accordance with the current Standard Specifications.

### **3.09 Modular Block (Segmental) Facing Units:**

This section covers dry-cast hollow and solid concrete masonry structural retaining wall units, machine made from Portland cement, water, and suitable mineral aggregates. The units are intended for use as facing units in the construction of mortarless, modular block walls (MBW) also known as segmental retaining walls (SRW). Metallic reinforcement specified in Section 3.02 shall be used as reinforcement in the reinforced (structure) wall fill zone.

#### **(A) Casting:**

Cementitious material in the modular block facing unit shall be Portland cement conforming to the requirements of ASTM C 150. If fly ash is used it shall not exceed 20% by weight of the total cement content and shall conform to ASTM C 618. Aggregates used in concrete blocks shall conform to ASTM C 33 for normal weight concrete aggregate. Efflorescence control agent shall be used in concrete mix design to prevent efflorescence on the block.

The contractor shall advise the Engineer of the starting date for concrete panel casting at least 14 calendar days prior to beginning the operation if the casting operation is within the State, or 21 calendar days if the casting operation is outside the State.

#### **(B) Physical Requirements:**

At the time of delivery to the work site, the modular block facing units shall conform to the following physical requirements:

- 1) Minimum required compressive strength of 4,000 psi (average 3 coupons)
- 2) Minimum required compressive strength of 3,500 psi (individual coupon)
- 3) Minimum oven dry unit weight of 125 pcf
- 4) Maximum water absorption of 5 % after 24 hours
- 5) Maximum number of blocks per lot of 2,000. Tests on blocks shall be submitted at the frequency of one set per lot.

Acceptance of the concrete block, with respect to compressive strength, water absorption and unit weight, will be determined on a lot basis. The lot shall be randomly sampled and tested in accordance with ASTM C140. As no additional expense to the Department, the manufacturer shall perform the tests at a Department approved laboratory and submit the results to the Engineer for approval. Compressive strength test specimens shall be cored or shall conform to the saw-cut coupon provisions of ASTM C 140. Block lots represented by test coupons that do not reach an average compressive strength of 4,000 psi will be rejected.

#### **(C) Freeze-Thaw Durability:**

In areas where repeated freezing and thawing under saturated conditions occur, the units shall be tested to demonstrate freeze-thaw durability in accordance with Test Method ASTM C1262. Freeze thaw durability shall be based on tests from five specimens made with the same materials, concrete mix design, manufacturing process, and curing method, conducted not more than 18 months prior to delivery. Specimens used for absorption testing shall not subsequently be used for freeze-thaw testing. Specimens shall comply with either or both of the following acceptance criteria depending on the severity of the project location as determined by the Department:

- 1) The weight loss of four out of five specimens at the conclusion of 150 cycles shall not exceed 1% of its initial weight when tested in water.

- 2) The weight loss of each of four out of the five test specimens at the conclusion of 50 cycles shall not exceed 1.5% of its initial mass when tested in a saline (3% sodium chloride by weight) solution.

**(D) Tolerances for Modular Block Dimensions:**

Modular blocks shall be manufactured within the following tolerances:

- 1) The length and width of each individual block shall be within  $\pm 1/8$  inch of the specified dimension. Hollow units shall have a minimum wall thickness of  $1/4$  inches.
- 2) The height of each individual block shall be within  $\pm 1/16$  inch of the specified dimension.
- 3) When a broken (split) face finish is required, the dimension of the front face shall be within  $\pm 1.0$  inch of the theoretical dimension of the unit.

**(E) Finish and Appearance:**

Units that indicate imperfect molding, honeycomb or open texture concrete and color variation on front face of block due to excess form oil or other reasons shall be rejected. All units shall be visually efflorescence free. All units shall be sound and free of cracks or other defects that would interfere with the proper placing of the unit or significantly impair the strength or permanence of the construction. Minor cracks (e.g. no greater than  $1/50$  inch in width and no longer than 25% of the unit height) incidental to the usual method of manufacture or minor chipping resulting from shipment and delivery, are not grounds for rejection.

The exposed faces shall be free of chips, cracks or other imperfections when viewed from a distance of 30 feet under diffused lighting. Up to five (5) percent of a shipment may contain slight cracks or small chips not larger than 1.0 inch.

Color and finish shall be as shown on the plans and shall be erected with a running bond configuration.

**(F) Pins:**

If pins are required to align modular block facing units, they shall consist of a non-degrading polymer or hot-dipped galvanized steel and be made for the express use with the modular block units supplied. Connecting pins supporting the reinforcement shall be hot-dipped galvanized steel and be capable of holding the reinforcement in the proper design position during backfilling.

**(G) Cap Units and Adhesive:**

The cap unit connection to the block unit immediately under it shall be of a positive interlocking type and not frictional. Cap units shall be cast to or attached to the top of modular block facing units in strict accordance with the requirements of the manufacturer of the blocks and the adhesive. The surface of the block units under the cap units shall be clear of all debris and standing water before the approved adhesive is placed. Contractor shall provide a written 10-year warranty, acceptable to Owner, that the integrity of the materials used to attach the cap blocks will preclude separation and displacement of the cap blocks for the warranty period.

**(H) Unit (Core) Fill:**

Unit (core) fill is defined as free-draining, coarse grained material that is placed within the empty cores of the modular block facing units. Unit (core) fill shall be a well graded crushed stone or granular fill meeting the gradation shown in Table 7. Gradation for unit fill shall be tested at the frequency of 1 test per 50 yd<sup>3</sup> at the job site and for every change in the material source.

**Table 7  
Gradation for Unit (Core) Fill**

U.S. Sieve Size	Percent Passing
1½-inch	100
1-inch	75-100
¾-inch	50-75
No. 4	0-60
No. 40	0-50
No. 200	0-5

**3.10 Certificate of Analysis for Modular Block Connection:**

For modular block facing units, a certification shall be provided with detailed calculations according to AASHTO and the results of laboratory test results performed in accordance with Section C.3 in Appendix B of FHWA NHI-10-025, dated 2009 (“Mechanically Stabilized Earth Walls and Reinforced Soil Slopes – Volume II”). Such certification shall demonstrate that all connections, including block-to-reinforcement and block-to-block connections, and all related components meet or exceed the current AASHTO 100 year design life requirements and are capable of resisting 100% of the maximum tension in the soil reinforcements at any level within the wall. Long-term connection testing for extensible reinforcements is also required. The effect of wall batter and normal pressures representative of the full range of wall configurations and heights shall be incorporated in the tests.

**4.0 CONSTRUCTION REQUIREMENTS:**

Construction of MSE walls may be subject to special requirements as specified in the Geotechnical Report and Geotechnical MSE Wall Note Sheets developed by the Design Build Team. These requirements may include but are not limited to: monitoring devices (refer to section 4.5), phased panel and reinforced fill construction, waiting period intervals and foundation modification.

**4.01 Excavation:**

The contractor shall ensure that temporary slopes are safe during the period of wall construction, and shall adhere to all applicable local, state and federal regulations. During construction of the MSE walls, the contractor shall design, construct, maintain and, when called for, remove temporary excavation support systems (shoring). Temporary excavation support systems may be left in place if approved by the Engineer. The back slope of the excavation shall be benched. Where shoring is required, the contractor shall submit the shoring design, and a plan outlining construction and removal procedures, to the Engineer for review and approval prior to proceeding with the work. Shoring plans shall be prepared and submitted as part of the working drawings and shall bear the seal and signature of a licensed Professional Engineer in the Commonwealth of Kentucky. All shoring design shall include appropriate input and review by a geotechnical engineer.

**4.02 Foundation Preparation:**

**(A) General:**

If required, specific ground improvement requirements shall be outlined in the Geotechnical Report and the Geotechnical Note Sheets.

In general the following applies:

The foundation for the reinforced wall fill and retained backfill shall be graded level for the entire area of the base of such backfills, plus an additional 12 inches on all sides, or to the limits shown in the plans. If soil reinforcement components are to be positioned on native soil, the top one (1) foot of native soil shall meet the requirements of the reinforced backfill material specified in Subsection 3.05.

Foundation replacement material shall consist of “Granular Embankment” meeting the requirements of Section 3.06 herein. The material shall be compacted in accordance with Section 206 of the current Standard Specifications except that the maximum loose lift thickness (prior to compaction) is 12 inches. Type IV Geotextile Fabric shall be placed between the existing embankment material and the proposed “Granular Embankment” in accordance with Sections 214 and 843 of the Standard Specifications.

**(B) Proof-Rolling:**

The contractor shall perform proof-rolling to evaluate the stability and uniformity of the subgrades on which the MSE structure will be constructed. Proof rolling shall be performed on the entire areas at the following locations:

- 1) At the bottom of the overexcavation and recompaction zones.
- 2) At the bottom of the overexcavation and replacement zones.
- 3) At the base of all walls.
- 4) At the top of native soil layers and/or existing fill material that has been scarified, moisture-conditioned, and recompacted (if different from the bottom of the overexcavation and recompaction zones, or overexcavation and replacement zones).

Proof-rolling shall be done immediately after subgrade compaction while the moisture content of the subgrade soil is near optimum, or at the moisture content that was used to achieve the required compaction. Proof-rolling shall be performed again within one day prior to beginning MSE Wall construction.

If proof-rolling is performed after installation of pipe underdrains, the proof-roller shall not be used within 1½ feet of the underdrains.

Proof-rolling shall be performed with a pneumatic-tired tandem axle roller with at least three wheels on each axle, a gross weight of 25 tons (50,000 pounds), a minimum tire pressure of 75 pounds per square inch, and a minimum rolling width of 75 inches. A Caterpillar PS-300B (or PF-300B), Ingersoll-Rand PT-240R, BOMAG BW24R, Dynapac CP271, or equipment with equivalent capabilities shall be used for proof-rolling.

Proof-rolling equipment shall be operated at a speed between 1.5 and 3 miles per hour, or slower as required by the Engineer to permit measurements and/or observations of the deformations, ruts and/or pumping.

Proof-rolling shall be carried out in two directions at right angles to each other with no more than 24 inches between tire tracks of adjacent passes. The contractor shall operate the proof-roller in a pattern that readily allows for the recording of deformation data and complete coverage of the subgrade.

The following actions shall be taken based on the results of the proof-rolling activity:

- 1) Rutting (i.e. deformation that does not rebound) less than ¼-inch – The grade is acceptable.
- 2) Rutting greater than ¼-inch and less than 1½ inches – The grade shall be scarified and re-compacted.
- 3) Rutting greater than 1½ inches – The compacted area shall be removed and reconstructed.
- 4) Pumping (i.e. deformation that rebounds, or materials that are squeezed out of a wheel’s path) greater than one (1) inch – The area shall be remediated as directed by the Engineer.

The contractor shall be responsible for maintaining the condition of the approved proof-rolled soils throughout the duration of the retaining wall construction. Wall construction shall not commence until



the foundation subgrade has been approved by the Engineer.

#### **4.03 Concrete Leveling Pad:**

Leveling pads shall be constructed of unreinforced Class B concrete meeting the requirements of Section 601 of the current Standard Specifications as shown on the working drawings. Gravel leveling pads shall not be allowed. The elevation of the top of leveling pad shall be within  $\frac{1}{8}$  inch from the design elevation when measured by a straightedge over any 10-foot run of the leveling pad.

The minimum width of the leveling pad shall be the width of the facing unit plus 8-inches. The centerline of the leveling pad shall be within 1 inch from design location. When the facing units are centered on the leveling pad, the leveling pad shall extend approximately 4-inches beyond the limits of the facing unit as measured in the direction perpendicular to the face of the wall.

Cast-in-place leveling pads shall be cured for a minimum of 48 hours before placement of wall facing units. A geotextile shall be applied over the back of the area of any openings greater than  $\frac{1}{4}$  inch between the facing units and leveling pad steps. The geotextile shall extend a minimum of six (6) inches beyond the edges of the opening. The opening shall be filled with Class B concrete, or shall be concurrently backfilled on both sides with soil.

#### **4.04 Subsurface Drainage:**

Prior to wall erection, the contractor shall install a subsurface drainage system as shown on the working drawings.

#### **4.05 Wall Erection:**

##### **(A) General:**

Walls shall be erected in accordance with the approved manufacturer's written construction procedures. The contractor shall be responsible for ensuring that a field representative from the manufacturer is available at the site during construction of the initial 10-foot height of the full length of wall for each wall system. Additionally the representative shall be present for the initial 10-foot height of the full length of wall for each wall system as constructed by each additional contractor, and as called upon thereafter by the Engineer, to assist the contractor and Engineer at no additional cost to the Department. All temporary construction aids (e.g., wedges, clamps, etc.) shall be in accordance with the manufacturer's recommendations.

##### **(B) Placement Tolerances for Walls with Precast Facing:**

For walls with rigid facing, such as precast concrete panels, the panels shall be placed such that their final position is vertical or battered as shown on the working drawings. As wall fill material is placed, the panels shall be maintained in the correct vertical alignment by means of temporary wedges, clamps, or bracing as recommended by the manufacturer. A minimum of two, but not more than three, rows of panel wedges shall remain in place at all times during wall erection. Wedges shall be removed from lower rows as panel erection progresses, so as to prevent chipping or cracking of concrete panels. The contractor shall repair any damage to erected concrete panels as directed by the Engineer and to the Engineer's satisfaction. No external wedges in front of the wall shall remain in place when the wall is complete.

Erection of walls with panel facing shall be in accordance with the following tolerances:

- Vertical and horizontal alignment of the wall face shall not vary by more than  $\frac{3}{4}$  inch when measured along a 10-foot straightedge.
- The overall vertical tolerance (plumbness) of the finished wall shall not exceed  $\frac{1}{2}$  inch per 10 feet of wall height. Negative (outward leaning) batter is not acceptable.

- The maximum permissible out of plane offset at any panel joint shall not exceed 3/8 inch.
- The final horizontal and vertical joint gaps between adjacent facing panel units shall be within 1/8 inch and 1/4 inch, respectively, of the design final joint opening per the approved calculations required in Subsection 3.01(H).

Wall sections not conforming to these tolerances shall be reconstructed at no additional cost to the Department.

**(C) Placement Tolerances for Permanent Walls with Flexible Facing:**

Permanent Flexible Facing is not allowed.

**(D) Placement Tolerances for Modular Block Units:**

Erection of walls with Modular Block Units shall be as per the following requirements:

- Vertical and horizontal alignment of the wall face shall not vary by more than 3/4-inch when measured along a 10-foot straightedge.
- Overall vertical tolerance (plumbness) of the wall shall not exceed 1 1/4-inch per 10-ft of wall height from the final wall batter. Negative (outward leaning) batter is not acceptable.
- The first row of units shall be level from unit-to-unit and from front-to-back. Use the tail of the units for alignment and measurement.
- All units shall be laid snugly together and parallel to the straight or curved line of the wall face.
- Unless otherwise noted, all blocks shall be dry-stacked and placed with each block evenly spanning the joint in the row below (running bond). Shimming or grinding shall control the elevations of any two adjacent blocks within 1/16 inch.
- The top of blocks shall be checked with a minimum length of 3-foot long straight edge bubble level. Any high points identified by the straight edge shall be ground flat. Block front to back tilting shall be checked frequently, however correction by shimming shall be done no later than 3 completed courses.
- Wall sections not conforming to these tolerances shall be reconstructed at no additional cost to the Department.

**(E) Placement of Metallic Reinforcement Elements:**

Metallic reinforcement elements shall be placed normal (perpendicular) to the face of the wall, unless otherwise shown on the approved plans. All reinforcement shall be structurally connected to the wall face.

At each level of the reinforcement, the reinforced wall fill material shall be roughly leveled and compacted before placing the next layer of reinforcement. The reinforcement shall bear uniformly on the compacted reinforced fill from the connection to the wall to the free end of the reinforcing elements. The reinforcement placement elevation shall be at the connection elevation to two (2) inches higher than the connection elevation.

Where overlapping of reinforcing may occur, such as at corners, reinforcing connections to panels shall be adjusted to maintain at least three (3) inches of vertical separation between overlapping reinforcement.

**(F) Placement of Geotextile:**

All joints between precast concrete panels shall be covered with geotextile on the backside of the wall. Adhesive shall be applied to panels only. Adhesive shall not be applied to geotextile fabric or within two (2) inches of a joint. The contractor shall provide geotextile having a minimum width of 12 inches, and shall overlap fabric a minimum of four (4) inches. If applicable, the placement of the geotextile fabric for modular block walls shall be in accordance with the plans.

**(G) Joint Pads and Fillers:**

The contractor shall install joint pads and fillers as shown on the working drawings.

**(H) Placement of Geosynthetic Reinforcement:**

Geosynthetic reinforcement is not allowed.

**4.06 Reinforced Wall Fill Placement:**

**(A) General:**

Reinforced wall fill material shall be compacted using a static-weighted or vibratory roller. Sheeps-foot or grid-type rollers shall not be used for compacting material within the limits of the fill reinforcement. Compaction within three (3) feet of the wall facing shall be achieved by a lightweight mechanical tamper or roller system.

Reinforced wall fill placement shall closely follow erection of each course of facing panels. Reinforced fill material shall be placed in such a manner to avoid damage or disturbance of the wall materials, misalignment of facing panels, or damage to fill reinforcement or facing members. The contractor shall place fill material to the level of the connection and in such a manner as to ensure that no voids exist directly beneath reinforcing elements.

If applicable, the fill material for walls with modular block facing units shall not be advanced more than the height of a modular block unit until the drainage fill, core fill and all fill in all openings within the blocks at that level have been placed. The filled units shall be swept clean of all debris before installing the next level of units and/or placing the geogrid materials

The maximum compacted lift thickness shall not exceed eight (8) inches. The contractor shall decrease this lift thickness, if necessary, to obtain the specified density.

For metallic reinforcements, the fill shall be spread by moving the machinery parallel to or away from the wall facing and in such a manner that the steel reinforcement remains normal to the face of the wall. Construction equipment shall not operate directly on the steel reinforcement. A minimum fill thickness of three (3) inches over the steel reinforcement shall be required prior to operation of vehicles. Sudden braking and sharp turning shall be avoided.

Wall materials which are damaged during reinforced fill material placement shall be removed and replaced by the contractor, at no additional cost to the Department. The contractor may submit alternative corrective procedures to the Engineer for consideration. Proposed alternative corrective procedures shall have the concurrence of the MSE wall supplier and designer, in writing, prior to submission to the Engineer for consideration. All corrective actions shall be at no additional cost to the Department.

**(B) Compaction Criteria:**

Trial fill sections shall be constructed with Department personnel present to determine appropriate criteria to achieve adequate compaction. The trial fill sections shall be performed as follows:

- One trial fill section is valid for up to 10,000 ft<sup>2</sup> of MSE wall area (e.g. 1 to 10,000 ft<sup>2</sup> of wall requires 1 trial fill section, 10,001 to 20,000 ft<sup>2</sup> requires 2, etc.) and for no more than one individual MSE wall.
- The minimum dimensions of the test pad shall be 15 ft. wide by 50 ft. long.
- The lift thickness shall not exceed eight (8) inches after compaction.
- Compaction shall be determined by using a level to measure the settlement of the trial section at a number of points after each pass (e.g., a minimum of 5 points measured at the center of a 1 ft square metal plate or other method approved by the Engineer).
- A thickness of approximately 2.5 feet shall be constructed to determine the appropriate number of passes, which will maximize compaction without excessively crushing the rock at the surface.
- The number of passes to achieve at least 80 percent of the maximum settlement will be required for production work.
- Only those methods used to establish compaction compliance in the trial fill section shall be used for production work.
- A material change, change in source, a difference of more than +/- 5.0 percent passing any sieve size, and/or change in the approved equipment shall require the contractor to conduct a new trial fill section and obtain re-approval by the Engineer of the minimum number of passes and rolling pattern.
- The Department reserves the right to use other test methods to evaluate the adequacy of the compaction criteria.
- The trial fill sections are incidental to the bid price for Retaining Wall.

Within three (3) feet of the wall facing, compaction criteria shall be determined using test pad sections with Department personnel present to determine appropriate criteria to achieve adequate compaction. The test pad sections shall be performed as follows:

- The minimum dimensions of the test pad shall be 5 ft. wide by 15 ft. long.
- The lift thickness shall not exceed eight (8) inches after compaction.
- Compaction shall be determined by using a level to measure the settlement of the test pad section at a number of points after each pass (e.g., a minimum of 3 points measured at the center of a 1 ft square plate or other method approved by the Engineer).
- A thickness of approximately 2.5 feet shall be constructed to determine the minimum number of passes of a lightweight mechanical tamper or roller system.
- The number of passes to achieve at least 80 percent of the maximum settlement will be required for production work.
- Only those methods used to establish compaction compliance in the test pad section shall be used for production work.
- A material change, change in source, a difference of more than +/- 5.0 percent passing any sieve size, and/or change in the approved equipment shall require the contractor to conduct a new test pad section.
- The test pad sections are incidental to the bid price for Retaining Wall.

**(C) Moisture Control:**

The free moisture content of the reinforced fill material, as determined by KM 64-306, shall not exceed 2.0% during compaction.

**(D) Protection of the Work:**

The contractor shall not allow surface runoff from adjacent areas to enter the wall construction site at any time during construction operations. In addition, at the end of each day's operation, the contractor shall slope the last lift of fill material away from the wall facing so that runoff is directed away from the structure. If the subgrade is damaged due to water or otherwise, such that it does not meet the requirements of Subsection 4.02, then as directed by the Engineer, the contractor shall rework and repair the damaged subgrade at no additional expense to the Department. The criteria in Subsection 4.02 shall be used to judge the adequacy of the repair. Rework and repair shall extend to a depth where undamaged work is encountered.

**4.07 Retained Backfill Placement:**

As required by the Geotechnical Report and plan notes the retained backfill (i.e. external backfill outside of the reinforced volume) may consist of either soil or "Granular Embankment" meeting the requirements of Section 3.06 herein. The material shall be compacted in accordance with Section 206 of the current Standard Specifications except that the maximum loose lift thickness (prior to compaction) is 12 inches. Type IV Geotextile Fabric shall be placed between the existing embankment material and the proposed "Granular Embankment" in accordance with Sections 214 and 843 of the Standard Specifications.

**4.5 MONITORING:**

**4.51 Monitoring Devices:**

The Geotechnical Report may require devices to monitor vertical and horizontal displacement both during and after construction. The Contractor will be responsible for providing labor and materials and for cooperating with, and providing, any required assistance to Department personnel with implementation of monitoring activities. The cost of all labor and materials required to support the monitoring program will be incidental to the cost of the.

The approximate locations of any monitoring devices shall be shown in the Working Drawings prepared by the MSE Wall Designer.

**4.52 Monitoring Schedule:**

The monitoring schedule for any required monitoring device shall be as agreed upon in the Geotechnical Report for the structure.

**5.0 METHOD OF MEASUREMENT:**

**5.01 MSE Retaining Wall:**

Mechanically Stabilized Earth (MSE) retaining walls will be measured by the square foot of Retaining Wall. The vertical height will be taken as the difference in elevation measured from the top of wall to the top of the leveling pad. No field measurement will be made. The final quantity will be the contract plan quantity increased or decreased by authorized changes.

The MSE Wall supplier's design may require additional excavation and MSE Wall materials to satisfy their design. The design MSE earth reinforcement lengths shall be equal to or greater than the length shown on the plans or as required by the AASHTO Specifications for the height of the wall plus live

load surcharge. The lengths of the MSE Reinforcement shall be constant from the bottom to the top of the section. Extension of the plan limits to accommodate the wall design, configuration of pre-fabricated concrete units, or lengths of earth reinforcement for MSE Walls shall not be cause for changing the plan pay quantities. Additional quantities of excavation, MSE Reinforcement, MSE volume, excavation for foundation replacement, granular embankment, and labor necessary to satisfy the MSE Wall supplier's design shall be incidental to the Retaining Wall.

The MSE volume that extends twelve inches, minimum, beyond the ends of the reinforced volume for MSE Walls shall be incidental to the Retaining Wall.

All work associated with providing the design, details and construction for the coping, moment slab, barrier and pre-cast aesthetic panel shall be incidental to the Retaining Wall.

All materials, equipment, and labor necessary to provide and install the geotextile fabric immediately surrounding the reinforced fill volume shall be incidental to the Retaining Wall.

### **5.02 Embankment:**

The quantity of embankment for external retained backfill behind the MSE Walls and, if required, granular foundation beneath the walls shall be measured according to Section 206 of the current Standard Specifications. The final quantities shall be based on field measurements.

### **5.03 Geotextile Fabric:**

All materials, equipment, and labor necessary to provide and install the geotextile fabric placed between existing fill material and Granular Embankment shall be measured according to Section 214 of the current Standard Specifications. The final quantities shall be based on field measurements.

| [Appendix:](#)

## APPENDIX I

### Resident Bidder Status

Solicitation/Contract #: \_\_\_\_\_

**REQUIRED AFFIDAVIT FOR BIDDERS, OFFERORS AND CONTRACTORS  
CLAIMING RESIDENT BIDDER STATUS**

**FOR BIDS AND CONTRACTS IN GENERAL:**

The bidder or offeror hereby swears and affirms under penalty of perjury that, in accordance with KRS 45A.494(2), the entity bidding is an individual, partnership, association, corporation, or other business entity that, on the date the contract is first advertised or announced as available for bidding:

1. Is authorized to transact business in the Commonwealth;
2. Has for one year prior to and through the date of advertisement
  - a. Filed Kentucky income taxes;
  - b. Made payments to the Kentucky unemployment insurance fund established in KRS 341.49; and
  - c. Maintained a Kentucky workers' compensation policy in effect.

The BIDDING AGENCY reserves the right to request documentation supporting a bidder's claim of resident bidder status. Failure to provide such documentation upon request shall result in disqualification of the bidder or contract termination.

\_\_\_\_\_  
Signature Printed Name

\_\_\_\_\_  
Title Date

Company Name \_\_\_\_\_

Address \_\_\_\_\_

\_\_\_\_\_

\_\_\_\_\_

Subscribed and sworn to before me by \_\_\_\_\_  
(Affiant) (Title)

of \_\_\_\_\_ this \_\_\_\_\_ day of \_\_\_\_\_, 20\_\_\_\_.  
(Company Name)

\_\_\_\_\_  
Notary Public

[seal of notary]

My commission expires: \_\_\_\_\_



## APPENDIX J

### Executive Branch Code of Ethics

## EXECUTIVE BRANCH CODE OF ETHICS

In the 1992 regular legislative session, the General Assembly passed and Governor Brereton Jones signed Senate Bill 63 (codified as KRS 11A), the Executive Branch Code of Ethics, which states, in part:

KRS 11A.040 (6) provides:

No present or former public servant shall, within six (6) months of following termination of his office or employment, accept employment, compensation or other economic benefit from any person or business that contracts or does business with the state in matters in which he was directly involved during his tenure. This provision shall not prohibit an individual from returning to the same business, firm, occupation, or profession in which he was involved prior to taking office or beginning his term of employment, provided that, for a period of six (6) months, he personally refrains from working on any matter in which he was directly involved in state government. This subsection shall not prohibit the performance of ministerial functions, including, but not limited to, filing tax returns, filing applications for permits or licenses, or filing incorporation papers.

KRS 11A.040 (8) states:

A former public servant shall not represent a person in a matter before a state agency in which the former public servant was directly involved, for a period of one (1) year after the latter of:

- a) The date of leaving office or termination of employment; or
- b) The date the term of office expires to which the public servant was elected.

This law is intended to promote public confidence in the integrity of state government and to declare as public policy the idea that state employees should view their work as a public trust and not as a way to obtain private benefits.

If you have worked for the executive branch of state government within the past six months, you may be subject to the law's prohibitions. The law's applicability may be different if you hold elected office or are contemplating representation of another before a state agency.

Also, if you are affiliated with a firm which does business with the state and which employs former state executive-branch employees, you should be aware that the law may apply to them.

In case of doubt, the law permits you to request an advisory opinion from the Executive Branch Ethics Commission, Room 136, Capitol Building, 700 Capitol Avenue, Frankfort, Kentucky 40601; telephone (502) 564-7954.